



# MECHANICAL SEAL



CONTACT INFO: 1-868-224-1510

ADDRESS: 26 SELLIER STREET ST. AUGUSTINE

EMAIL US: [INFO@ACCURATEINDUST.COM](mailto:INFO@ACCURATEINDUST.COM)

FIND US ON FACEBOOK: [facebook.com/AccurateIndustrialSupplies](https://www.facebook.com/AccurateIndustrialSupplies)

## SEAL MFG. HEAD TYPES



**Type A**

Equal to:  
John Crane  
Type 6



**Type B**

Equal to:  
John Crane  
Type 6A

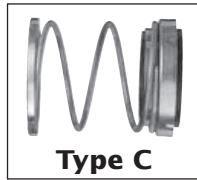

**Type C**

Equal to:  
John Crane  
Type 21

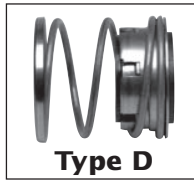

**Type D**

Equal to:  
John Crane  
Type 2

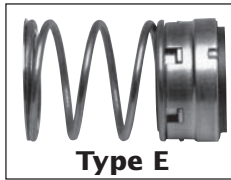

**Type E**

Equal to:  
John Crane  
Type 1

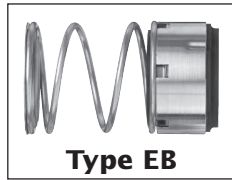

**Type EB**

Equal to:  
John Crane Type 1  
Balanced

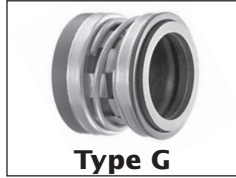

**Type G**

Equal to:  
John Crane Types  
2100 & 2106

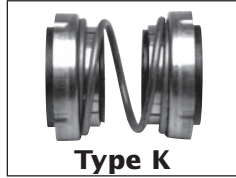

**Type K**

Equal to:  
John Crane  
Type 21 Double



**Type Q**

Equal to:  
John Crane  
Type 11A

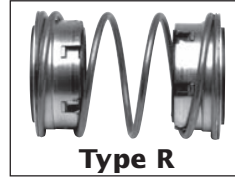

**Type R**

Equal to:  
John Crane  
Type 2 Double

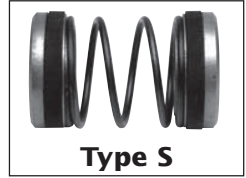

**Type S**

Equal to:  
John Crane  
Type 8 Special

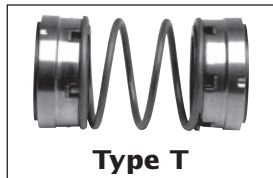

**Type T**

Equal to:  
John Crane  
Type 1 Double

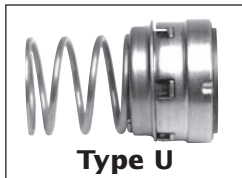

**Type U**

Equal to:  
John Crane  
Type 1 w/ Spring Adapter

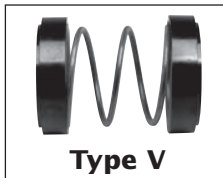

**Type V**

Equal to:  
John Crane  
Type 8D

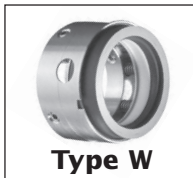

**Type W**

Equal to:  
John Crane  
Types 9 & 9T



**Type X**

Equal to:  
John Crane  
Types 8-1 & 8-1T

## SEAL MFG. MATING RING DESIGNS

(Available in a wide variety of materials)

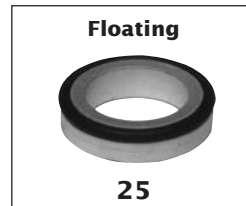
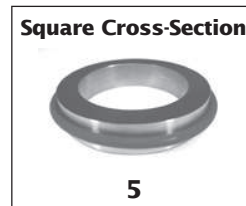
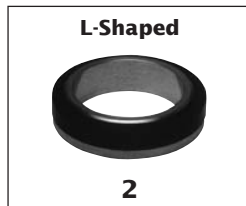

# SEAL MFG

## QUALITY MECHANICAL SEALS

Our seals are designed to give long life, provide automatic self-adjustment and reduce maintenance costs. Additionally, mechanical seals offer these important advantages.



### **ABSOLUTE SEALING**

Proper selection and installation of our seals results in less pumpage loss, cleaner facilities, less fire hazard, no danger from fumes and no contamination of the fluid being pumped.



### **NO RUBBING FRICTION BETWEEN SHAFT AND SEAL PARTS**

Replace packing with a mechanical seal and avoid expensive shaft or sleeve replacements.



### **FLEXIBLE SEALS MEANS LONGER SERVICE LIFE**

Compared to packing, mechanical seals are more flexible, and are able to compensate for shaft deflection, axial and radial end play, vibration and seal face wear.



### **LESS FRICTION MEANS VALUABLE POWER SAVINGS**

Mechanical seals use less friction than packing. Therefore, they require less horsepower consumption.



### **PRECISION LAPPED SEALING SURFACES**

Positively control leakage and eliminate "break in" runs.

### **HIGHER SPEEDS AND PRESSURES**

Our seals are designed for higher speeds and pressures.



### **FLAT SURFACES OF MATING FACES**

Sealing surfaces are precision lapped to a flatness of one to three light bands, which maintains the necessary face film lubrication, resulting in positive leakage control.

### **BROAD SELECTION OF MATERIALS OF CONSTRUCTION**

Our seals come in a wide variety of materials. Choose the correct combination of elastomer, metallurgy and sealing faces for your application. See pages 106-110 for the Material Recommendation Chart.

### **MECHANICAL SEALS CAN BE FOUND IN ...**

- Centrifugal Pumps
- Compressors
- Gear Boxes
- Gear Pumps
- Jet Pumps
- Petrochemical Pumps
- Pool and Spa Pumps
- Progressive Cavity Pumps
- Rotary Lobe Pumps
- Slurry Pumps
- Submersible Pumps
- Turbine Pumps

# FEATURES OF SEAL TYPES A, B, C, D, E, G, Q, W, X

## TYPE A (Seal Sizes .312-1.000)

**FEATURES:** Compact, unitized, single spring, elastomer bellows seal. The factory-assembled, one piece design permits fast, easy installation and the full-convolution elastomer bellows provides maximum flexibility in compensating for shaft movement and wear.

**SERVICES:** Centrifugal water pumps, deep and shallow well jet pumps, swimming pool and wastewater pumps. Pressures to 75 PSI. Temperature: -40°F to +400°F.



## TYPE B (Seal Sizes .375-1.000)

**FEATURES:** A full-convolution elastomer bellows provide maximum flexibility in compensating for shaft movement while torsional stress on the bellows is controlled by a dent and groove positive drive arrangement.

**SERVICES:** Centrifugal water pumps, sump pumps, submersible and swimming pool pumps. Pressures to 75 PSI. Temperature: -40°F to +400°F.



## TYPE C (Seal Sizes .312-5.500)

**FEATURES:** Elastomer bellows seal, non-clogging, single coil spring, The drive band's notch design eliminates overstressing of the bellows.

**SERVICES:** Rotary and turbine pumps, compressors, mixers, blenders and chillers. Pressures to 150 PSI. Temperature: -40°F to +400°F.



## TYPE D, E (Seal Sizes .500-5.625)

**FEATURES:** Self adjusting elastomer bellows compensate for abnormal shaft end play and primary face sealing wear. Effects of radial and axial shaft end play are minimized by uniform spring pressure.

Positive drive is transmitted through the drive band and drive notches, which absorb breakout and running torque. Damaging stresses on the elastomer bellows are prevented. Slippage is eliminated, thus protecting shaft and sleeve against wear and scoring. The result is long seal life.

The seal's large single-coil spring is much sturdier than a multiple spring construction design. The spring is non-clogging, self-cleaning and will not foul up due to fluid contact. Corrosion and clogging problems are eliminated.

**SERVICES:** All types of rotary shaft equipment such as pumps, mixers, blenders, and compressors. Wide range of services from water and steam to chemicals and corrosives.

Pressures to 350 PSI. Temperature: -40°F to +425°F

Balanced Seals - Pressures to 1200 PSI. Temperature: -40°F to +450°F

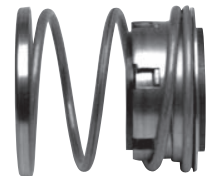

TYPE D



TYPE E

## TYPE G (Seal Sizes .437-3.500)

**FEATURES:** A compact unitized single spring elastomeric bellows shaft seal. Innovative full convolution bellows and interlocking drive band design allows for positive drive and greater tolerance to misalignment. Interference fit of primary ring insures positive drive while avoiding high face distortions associated with crimped designs.

**SERVICES:** Small centrifugal pumps used in Pool & Spa, Well Water, & HVAC applications. Pressures to 150 PSI. Temperature -30°F to +300°F.



## TYPE Q (Seal Sizes .500-2.250)

**FEATURES:** Press fitted, rubber diaphragm protects metal components, spring loaded

**SERVICES:** Icemaker and appliance applications, general purpose food service.

Pressures to 30 PSI. Temperature -40°F to +400°F.



## TYPE W (Seal Sizes .500-6.000)

**FEATURES:** Multi Spring, PTFE wedge design for use in extreme temperatures / chemical applications. Unitized construction. Also available in a balanced design

**SERVICES:** Corrosive fluid applications, extreme temperatures. Pressures to 350 PSI. Temperature -75°F to +500°F.



## TYPE X (Seal Sizes .250-6.000)

**FEATURES:** Multi Spring, O-ring design, unitized construction, flexible design compensates for shaft misalignment for high performance and longer seal life. Also available in a balanced design.

**SERVICES:** Wide usage in chemicals and corrosives. Pressures to 350 PSI. Temperature -20°F to +400°F.



# SEAL SIZING GUIDE

1. Remove seal to be replaced from shaft and/or sleeve.
2. Make note of materials used for the old seal parts using Seal Mfg. Material Code found in the front of this catalog.
3. Identify Head type (see front cover fold-out.) Use caliper to measure inside diameter (ID) and outside diameter (OD).

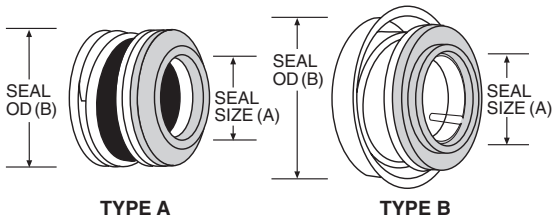

## SEAL HEADS – TYPES A and B

- Identify seal head type - Determine Seal Size:
- Measure the inside diameter (ID) (dimension A)
- Measure the outside diameter (OD) (dimension B)

The operating height is generally the same for all A and B seals of the same shaft size. More positive identification will result from calculating the mating ring dimensions below. If unable to positively identify the seal, consult U.S. Seal Mfg.

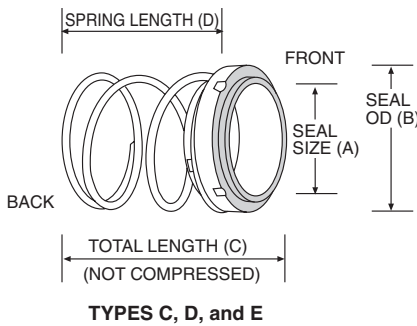

## SEAL HEADS – TYPES C, D and E

- Identify seal head type - Determine Seal Size:
- Measure ID of the bellows (dimension A) as installed in the seal head. Add approximately .016" additional for rubber squeeze.
- Measure the head OD (dimension B)
  - Step 1. Measure the total free length (dimension C) of the rotating portion of the assembled seal. (Do not include the mating ring).
  - Step 2. Disassemble seal and measure the free length of the spring (dimension D).
  - Step 3. Take half of the measurement obtained in step 2.
  - Step 4. Subtract the figure obtained in step 3 from the measurement (dimension C) in step 1. The result is the approximate operating height of the seal.

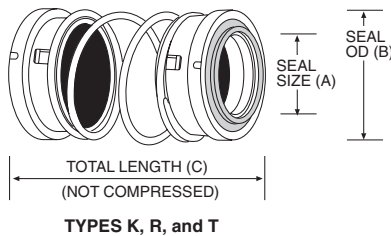

## SEAL HEADS – TYPES K, R and T

- Identify seal head type - Determine Seal Size:
- Measure the inside diameter of the bellows (dimension A).
- Add approximately .016" additional for rubber squeeze.
- Measure the head OD (dimension B)
- Calculate the operating height of the seal as follows:
  - Step 1. Measure the total length of the rotating seal (dimension C). (Not compressed).
  - Step 2. Multiply the total length (dimension C) by .73. The result is the approximate operating height of the seal.

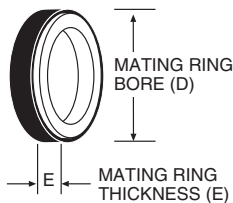

## MATING RING and GASKET

- Identify the mating ring design from those shown on inside of front cover.
- Measure OD of the gasket while assembled on mating ring and subtract approximately .016" additional for rubber squeeze to obtain bore dimension (dimension D).
- Measure the combined insert and gasket width (dimension E).
- Use the Dimensional Cross Reference guide (pages 112-161) to find the part number of the seal you need. Start with Seal Size and find the line in the tables that matches the dimensions and material code.

**ROTARY SEAL ASSEMBLY**

All metal parts including spring- retainers are 304ss in the Following Types:

A,B,C,D,F,J,K,N,Q,R

All metal parts including spring-retainers are 316ss in the Following Types:

E,L1,L2,T,U,Z

**SEAL FACES**

All seals shown come standard with various types of carbon faces unless noted as follows:

B- Bronze  
SC- Silicon Carbide  
SS- Stainless Steel  
TC -Tungsten Carbide

Other seal faces available on order such as ceramic, and metal w/hard face spray coated.

**ELASTOMERS**

All seals shown come standard With nitrile (Buna) elastomers unless a letter is designated at end of part number as follows:

E - EPR  
N- NEOPRENE  
TF-TEFLON  
V-VITON

**SEATS**

B - Bronze  
C - Ceramic  
CA - Carbon  
CS - Ceramic/Stainless  
SC - Silicon Carbide  
SS - Stainless Steel  
TC - Tungsten Carbide

Other seats are available on order such as carbon, metal w/hard face spray coated. SC or TC inserted into metal retainer.

**DIMENSIONAL CROSS REFERENCE BY SHAFT SIZE**

Part No.	Type	O.D.	OP. Height	Type	C' Bore	Thk.	Part No.	Type	O.D.	OP. Height	Type	C' Bore	Thk.
<b>.312 SHAFT</b>							<b>.375 SHAFT</b>						
<b>ROTARY</b>							<b>ROTARY</b>						
<b>SEAT</b>							<b>SEAT</b>						
114	C	.812	.656	1C	1.000	.312	2051AN	C	.812	.750	1B	1.312	.312
1064	C	.812	.812	3C	.875	.312	2400A	C	.812	.900	1C	1.000	.375
1064V	C	.812	.812	3C	.875	.312	3100A	C	.812	.750	----	----	----
3102X	C	.812	.640	----	----	----	5025AN	C	.812	.900	1C	.875	.219
3103X	C	.812	.640	1C	.750	.250	7845A	C	.812	.812	----	----	----
							030400X	C	.812	.750	1C	.875	.284
<b>.375 SHAFT</b>							1400A	L-1	.750	.850	8B	.563	.281
377	A	.937	.640	----	----	----							
511	A	.937	.640	1SS	.875	.218							
1614X	A	.937	.656	1C	1.000	.312	160	M	.906	SP	1C	1.000	.375
5055ATF	A	.937	.640	1CTF	.875	.219	170	M	.906	SP	2SS	1.000	.375
03030X	A	.937	.640	1C	.875	.281							
03040X	A	.937	.640	1C	.875	.281							
							<b>.437 SHAFT (11MM)</b>						
671	B	1.125	.375	1C	.875	.165	117 N	C	.875	1.250	1C	1.000	.312
718	B	1.125	.375	9SS	----	.240	174	C	.875	.718	1SS	1.175	.240
1046A	B	1.125	.375	1C	.875	.240	1069AN	C	.875	1.250	3SS	1.000	.312
1071	B	1.125	.375	1C	.875	.312	1133N	C	.875	.750	1C	1.181	.285
1615	B	1.125	.375	1C	1.000	.203	3578V	C	.875	.718	1	1.175	.240
1616	B	1.125	.375	9C	----	.190	2410AN	C	.875	1.400	1C	1.000	.703
0301X	B	1.125	.375	----	----	----	4800AN	C	.875	.750	1C	1.187	.265
0302X	B	1.125	.375	----	----	----	8475A	C	.875	.750	1C	1.187	.265
0303X	B	1.125	.375	----	----	----	9190A	C	.875	1.250	3C	1.000	.312
0304X	B	1.125	.375	1C	.875	.160	0401X	C	.875	.750	----	----	----
0308X	B	1.125	.375	1B	.875	.160	0402XN	C	.875	.750	----	----	----
0309X	B	1.125	.375	1SS	.875	.240	0404X	C	.875	.750	1C	1.000	.312
0310X	B	1.125	.375	1C	.875	.160	0409X	C	.875	.750	1C	1.181	.254
							0409XE	C	.875	.750	1C	1.181	.254
							0410X	C	.875	.750	3SS	1.181	.250
							0411X	C	.875	.690	----	----	----
0312X	C	.812	.750	1C	1.000	.250	0418XN	C	.875	.750	3SS	1.181	.250
0318X	C	.812	.750	1SS	.875	.284	0426X	C	.875	.750	3C	1.000	.312
302XN	C	.812	.750	----	----	----							
1025	C	.812	.588	1C	1.000	.192							
1064AN	C	.812	1.125	1SS	.825	.625	4265AN	L-2	.812	1.625	----	----	----
1065	C	.812	.812	3C	.875	.312							
1065V	C	.812	.812	3C	.875	.312							
1074A	C	.812	.600	1C	.875	.219							
1403A	C	.812	.812	1B	.875	.375							

Part No.	Type	O.D.	OP. Height	Type	C' Bore	Thk.	Part No.	Type	O.D.	OP. Height	Type	C' Bore	Thk.
<b>.500 SHAFT</b>							<b>.500 SHAFT</b>						
<b>ROTARY</b>				<b>SEAT</b>			<b>ROTARY</b>				<b>SEAT</b>		
162	A	1.062	.656	1C	1.000	.312	106	C	.937	.812	1SS	1.000	.290
280	A	1.062	.687	2B	1.125	.593	190	C	.937	.812	3SS	1.500	.26
298	A	1.062	.656	----	----	----	221	C	.937	.781	2SS	1.375	.187
506	A	1.062	.656	1SS	1.000	.290	392	C	.937	.781	1C	.938	.225
670	A	1.062	.656	3SS	.875	.218	392V	C	.937	.781	1C	.938	.225
1040A	A	1.062	.656	1SS	1.000	.312	393	C	.937	.718	1SS	.938	.225
2800A	A	1.062	.656	1C	1.125	.593	400	C	.937	.718	----	----	----
2800AV	A	1.062	.656	1C	1.125	.593	400A	----	----	----	1C	.938	.225
5120A	A	1.062	.656	3SS	1.000	.312	400V	C	.937	.718	----	----	----
8700A	A	1.062	.656	11CS	1.000	.312	401	C	.937	.812	----	----	----
0502X	A	1.062	.656	----	----	----	401A	C	.937	.812	1C	.938	.225
0504X	A	1.062	.656	1C	1.000	.312	420	C	.906	.718	2B	1.062	.290
0523X	A	1.062	.656	3C	1.000	.312	504	C	.937	.718	2B	1.062	.250
							631	C	.937	.812	1C	1.000	.312
							632	C	.937	.812	1SS	1.000	.290
142	B	1.125	.537	1C	1.000	.218	984	C	.937	.812	1SS	.938	.250
149	B	1.125	.537	8SS	M.O.S.	.062	985	C	.937	.812	1C	1.125	.230
150	B	1.125	.537	----	----	----	1002	C	.937	.812	1C	1.000	.312
155	B	1.125	.537	8SS	M.O.S.	.125	1002E	C	.937	.812	1C	1.000	.312
163	B	1.125	.537	1C	1.000	.312	1002V	C	.937	.812	1C	1.000	.312
164	B	1.125	.537	9SS	M.O.S.	.312	1005AN	C	.937	.625	----	----	----
165	B	1.125	.537	9C	M.O.S.	.312	1012	C	.937	.812	1C	.938	.225
489	B	1.125	.513	1C	1.250	.406	1043	C	.937	.718	1C	1.000	.218
788	B	1.125	.537	1SS	1.000	.290	1043A	C	.937	.718	1B	1.062	.344
1036A	B	1.125	.537	1SS	1.000	.312	1050	C	.937	.812	----	----	----
1037A	B	1.125	.537	1C	1.000	.560	1050A	C	.937	.718	1B	1.187	.203
1073A	B	1.125	.537	SP	M.O.S.	.201	1050AV	C	.937	.718	1B	1.187	.203
1075A	B	1.125	.537	11CS	M.O.S.	.342	1055AN	C	.937	.718	1B	1.312	.312
1078AE	B	1.125	.537	1C	1.000	.281	1065AN	C	.937	.718	1SS	1.000	.250
1079A	B	1.125	.537	7C	M.O.S.	.295	1070A	C	.937	.718	1SS	1.062	.312
1082AV	B	1.125	.537	7C	M.O.S.	.295	1084A	C	.937	.812	3SS	1.125	.312
1098	B	1.125	.537	1C	.875	.165	1120	C	.937	.718	1C	1.062	.312
1137	B	1.125	.418	1C	1.000	.187	1900AN	C	.937	.718	3SS	1.500	.297
1149	B	1.125	.537	9C	M.O.S.	.212	2050A	C	.937	.718	1B	1.187	.203
1500AV	B	1.125	.537	----	----	----	2138	C	.937	.605	SPSS	1.360	.300
1550A	B	1.125	.537	8SS	M.O.S.	.123	2320AN	C	.937	.718	54	1.375	PLT
1630AV	B	1.125	.537	1C	1.000	.312	2420A	C	.937	1.200	1C	1.000	.312
1640A	B	1.125	.537	7SS	M.O.S.	.295	3843	C	.937	.625	1	.938	.218
1643A	B	1.125	.537	1C	1.000	.279	3844	C	.937	.625	1	.938	.213
6300A	B	1.125	.537	10SS	M.O.S.	.342	4003AE	C	.937	.718	----	----	----
0506X	B	1.125	.537	----	----	----	4011A	C	.937	.718	11CS	.875	.205
							4011AV	C	.937	.718	11CS	.875	.205
							4200AN	C	.937	.718	1B	1.062	.250
							4625AN	C	.937	.718	----	----	----
							5040AN	C	.937	.656	1B	1.062	.350
							5300A	C	.937	USE EXISTING SPRING			----
							5350A	C	.937	.656	51SS	.995	PLT
							6710A	C	.937	.656	3SS	.875	.218
							6935A	C	.937	.875	1B	1.125	.375
							7526A	C	.937	.605	1B	1.000	.250
							9030AN	C	.937	.718	1SS	1.000	.312
							9956A	C	.937	.656	1SS	1.125	.250
							0507X	C	.937	.718	2B	1.062	.375
							0536XV	C	.937	.718	2SC	1.093	.190
							1539X	C	.937	.718	1SS	1.000	.203
							0555X	C	.937	.812	1SS	1.000	.312
							0589X	C*	.937	.605	1SS	1.000	.312
							05060X	C*	.937	.605	1C	1.000	.312
							7712	C	.937	.750	1	1.125	.237

Part No.	Type	O.D.	OP. Height	Type	C' Bore	Thk.	Part No.	Type	O.D.	OP. Height	Type	C' Bore	Thk.
<b>.500 SHAFT</b>							<b>.562 SHAFT</b>						
<b>ROTARY</b>				<b>SEAT</b>			<b>ROTARY</b>				<b>SEAT</b>		
168	E	.937	.831	1C	1.000	.312	9464A	F	1.109	.590	8SS	1.188	.406
666	E	.937	.831	1SS	1.000	.290	9465A	F	1.109	.590	8SS	1.240	.406
930	E	.937	.831	----	----	----	9466A	F	1.109	.590	8SS	1.240	.406
1045A	E	.937	.875	1C	1.000	.316	9467A	F	1.109	.590	8C	1.238	.302
1080A	E	.937	.831	3C	1.000	.281	9471	F	1.109	.590	8C	1.238	.302
1086A	E	.937	1.140	1SS	1.000	.312							
1628	E	.937	1.140	14SS	1.000	.656							
1629	E	.937	1.140	SPEC	1.000	.687	1607	K	1.062	1.187	----	----	----
2420AN	E	.937	1.140	1C	1.000	3.12							
6950AN	E	.937	1.140	54	.995	PLT							
0533X	E	.937	1.090	2SS	1.250	.576	2100AN	L-1	1.062	NO SPRG	52CA	----	PLT
0590X	E	.937	.530	3SS	1.000	.312	2102AN	L-1	1.062	NO SPRG	52	----	PLT
							7980AN	L-1	.938	.950	----	----	----
1071A	K	.937	.975	----	----	----	1090AN	L-2	.938	1.625	----	----	----
1083A	K	.937	1.125	1C	1.000	.312							
0583X	K	.937	1.125	1SS	1.000	.312							
0586X	K	.937	1.125	----	----	----							
							<b>.578 SHAFT</b>						
							1408A	C	1.062	.670	1C	1.250	.406
							<b>.590 SHAFT (15MM)</b>						
1015AN	L-2	.875	1.225	----	----	----	7520V	C	1.062	.875	1SS	1.250	.406
1025A	L-2	.875	1.675	----	----	----							
1077AN	L-2	.875	1.175	----	----	----	129	D	1.312	.875	1C	1.250	.406
							138	D	1.312	1.156	5SS	1.093	.406
663	Q	1.125	.390	1C	1.000	.312	1675	D	1.312	.875	1SS	1.250	.406
749	Q	1.125	.390	1C	.937	.225	5938A	D	1.312	.875	3SS	1.170	.250
1112	Q	1.125	.390	9C	----	.312	7520	C	1.062	.875	1	1.250	.406
1149	Q	1.125	.408	9	----	.218	20719XN	D	1.312	1.043	----	----	----
1621	Q	1.125	.390	9C	----	.171	05902X	D	1.312	.1250	----	----	----
0510X	Q	1.125	.390	----	----	----							
0517XE	Q	1.125	.390	1C	1.000	.312							
							<b>.594 SHAFT</b>						
							1110AN	L-1	1.000	1.130	----	----	----
							<b>.625 SHAFT</b>						
							100	A	1.218	.718	1C	1.187	.343
4330A	T	.937	1.425	1C	1.000	.312	100V	A	1.218	.718	1C	1.187	.343
0585X	T	.937	1.425	1SS	1.000	.312	100VOR	A	1.218	.718	3C	1.187	.343
0587X	T	.937	1.425	----	----	----	148	A	1.218	.718	1SS	1.125	.500
							153	A	1.218	.811	1SS	1.250	.406
							153VOR	A	1.218	.811	3SS	1.250	.406
<b>.562 SHAFT</b>							166	A	1.218	.811	1C	1.187	.343
1061	A	1.218	.718	1	1.250	.406	198	A	1.218	.718	8SS	----	.125
500N	C	1.062	.812	2B	1.031	.312	200	A	1.218	.718	1C	1.250	.406
558N	C	1.062	.812	1SS	1.000	.290	200E	A	1.218	.718	1	1.250	.406
928N	C	1.062	.812	----	----	----	200V	A	1.218	.718	1C	1.250	.406
1095AN	C	1.062	.750	52	----	PLT	200VOR	A	1.218	.718	3C	1.250	.406
1096AN	C	1.062	.750	----	----	----	218	A	1.218	.718	----	----	----
1105AN	C	1.062	.750	1SS	1.000	.312	232	A	1.218	.718	3SS	1.207	.250
3542	C	1.000	.808	3	1.031	.312	293	A	1.218	.718	P-IN	.815	.312
3911A	C	1.062	.875	50	.938	PLT	299	A	1.218	.718	----	----	----
4335AN	C	1.062	.812	3SS	1.031	.281	300	A	1.218	.718	1C	1.250	.406
9705AN	C	1.062	.700	1SS	1.312	.312	300VOR	A	1.218	.718	3C	1.250	.406
05607X	C	1.062	.812	1C	1.187	.343	372	A	1.218	.718	1SS	1.250	.250
05610X	C	1.062	.875	----	----	----	425	A	1.218	.812	1C	1.250	.406
05613X	C	1.062	.800	3SS	1.125	.410	442	A	1.218	.718	1C	1.312	.250



Part No.	Type	O.D.	OP Height	Type	C° Bore	Thk.	Part No.	Type	O.D.	OP. Height	Type	C° Bore	Thk.
.625 SHAFT							.625 SHAFT						
ROTARY				SEAT			ROTARY				SEAT		
501	A	1.218	.811	1C	1.250	.406	8710A	A	1.218	.718	11CS	1.250	.406
501VOR	A	1.218	.811	3C	1.250	.406	9070A	A	1.218	.718	1SS	1.250	.250
507	A	1.218	.718	1SS	1.250	.406	9071A	A	1.218	.718	1C	1.250	.250
507VOR	A	1.218	.718	3SS	1.250	.406	9900A	A	1.218	.718	1B	1.312	.312
516	A	1.218	.718	1C	1.250	.406	0619X	A	1.218	.812	----	----	----
518	A	1.218	.718	1SS	1.187	.288	0630X	A	1.218	.812	----	----	----
524	A	1.218	.718	1SS	1.250	.406	0672XX	A	1.218	.718	1SC	1.250	.406
524E	A	1.218	.718	1SS	1.250	.406	06987XX	A	1.218	.718	1TC	1.187	.343
528	A	1.218	.718	1C	1.375	.562							
528V	A	1.218	.718	1C	1.375	.562							
551	A	1.218	.718	1C	1.250	.283							
628	A	1.218	.718	3SS	1.250	.406	113	B	1.437	.615	1C	1.093	.218
637	A	1.218	.718	3C	1.250	.406	151	B	1.437	.615	1C	1.375	.288
680	A	1.218	.718	1C	1.187	.288	200A	B	1.437	.615	1C	1.250	.283
701	A	1.218	.718	1SS	1.187	.288	202	B	1.437	.615	11CS	----	.375
701V	A	1.218	.718	1SS	1.187	.288	202V	B	1.437	.615	11CS	----	.375
702	A	1.218	.718	1C	1.187	.288	233	B	1.437	.615	1C	1.312	.250
702V	A	1.218	.718	1C	1.187	.288	260	B	1.437	.615	11CS	----	.375
656-711	A	1.218	.718	3C	1.187	.343	409	B	1.437	.615	8SS	----	.187
711CA-AV	A	1.218	.718	3SS	1.187	.343	411	B	1.437	.615	11CS	----	.487
896	A	1.218	.718	3C	1.187	.343	411P	B	1.437	.615	11CS	----	.487
920	A	1.218	.718	1SS	1.141	.312	411V	B	1.437	.615	11CS	----	.487
952	A	1.218	.811	1C	1.250	.406	414	B	1.437	.615	11CS	----	.328
953	A	1.218	.811	1C	1.187	.343	447	B	1.437	.615	9C	----	.215
954	A	1.218	.811	1SS	1.250	.406	447V	B	1.437	.615	9C	----	.215
955	A	1.218	.811	1SS	1.187	.288	451	B	1.437	.615	9SS	----	.320
957	A	1.218	.718	1C	1.187	.343	452	B	1.437	.615	9C	----	.312
1006A	A	1.218	.718	8C	1.094	.312	453	B	1.437	.615	9SS	----	.215
1061A	A	1.218	.718	1TC	1.250	.406	522	B	1.437	.615	1SS	----	.288
1061AV	A	1.218	.718	1TC	1.250	.406	600	B	1.437	.615	1C	----	.343
1114	A	1.218	.811	P-IN	1.096	.312	600V	B	1.437	.615	3C	----	.343
1116AV	A	1.218	.718	1SS	1.250	.437	616	B	1.437	.615	1SS	----	.288
1121A	A	1.218	.718	1C	1.375	.461	642	B	1.437	.615	----	----	----
1121AV	A	1.218	.718	1C	1.375	.461	700	B	1.437	.615	1C	1.187	.288
1126A	A	1.218	.718	1C	1.150	.295	712	B	1.437	.615	3SS	1.250	.406
1150	A	1.218	.718	1SS	1.187	.343	715	B	1.437	.615	3C	1.250	.406
1160A	A	1.218	.718	3SS	1.125	.459	716	B	1.437	.615	3C	1.187	.288
1185A	A	1.218	.812	1C(TF)	1.250	.406	717	B	1.437	.615	3C	1.187	.343
1212A	A	1.218	.812	8C	1.081	.312	720	B	1.437	.615	9CS	----	.343
1240A	A	1.218	.718	3C	1.187	.312	882	B	1.437	.615	----	----	----
1240AV	A	1.218	.718	3C	1.187	.341	961	B	1.437	.615	1C	1.250	.406
1241AE	A	1.218	.718	3C	1.187	.341	963	B	1.437	.615	1C	1.187	.343
1243AE	A	1.218	.718	1SS	1.250	.250	964	B	1.437	.615	1SS	1.250	.406
1244A	A	1.218	.718	3C	1.187	.406	1000	B	1.437	.615	1C	1.250	.406
1249A	A	1.218	.875	1C	1.250	.437	1000V	B	1.437	.615	1C	1.250	.406
2000AE	A	1.218	.718	1C	1.250	.406	1005A	B	1.437	.615	1SS	1.375	.406
2002AV	A	1.218	.718	1SS	1.250	.406	1013V	B	1.437	.615	11CS	----	.375
2131	A	1.218	.718	----	----	----	1021	B	1.437	.615	9C	----	.215
2204	A	1.218	.718	1	1.250	.406	1089V	B	1.437	.615	1C	1.093	.406
2321A	A	1.218	.718	3SS	1.187	.250	1129	B	1.437	.615	1SS	1.187	.343
3000A	A	1.218	.950	1C	1.250	.406	1147A	B	1.437	.615	8C	----	.215
3000AV	A	1.218	.950	1C	1.250	.406	1151	B	1.437	.615	2SS	1.250	.343
3816	A	1.218	.843	1	1.250	.406	1152	B	1.437	.615	1SS	1.250	.406
3864	A	1.218	.811	1	1.250	.406	1246A	B	1.437	.615	9C	----	.307
4165A	A	1.218	.718	1B	1.312	.343	2161	B	1.437	.615	1C	1.375	.406
4705A	A	1.218	.718	1C	1.320	.343	3865	B	1.437	.615	1	1.250	.406
5200A	A	1.218	.718	1SS	1.125	.484							
5955A	A	1.218	.718	1SS	1.312	.469							
7000AE	A	1.218	.718	1C	1.187	.296							

Part No.	Type	O.D.	OP. Height	Type	C' Bore	Thk.	Part No.	Type	O.D.	OP. Height	Type	C' Bore	Thk.
<b>.625 SHAFT</b>							<b>.625 SHAFT</b>						
<b>ROTARY</b>				<b>SEAT</b>			<b>ROTARY</b>				<b>SEAT</b>		
4112A	B	1.437	.615	1C	1.187	.296	1112A	C	1.062	.665	1C	1.312	.312
4112AV	B	1.437	.615	1C	1.187	.296	1115AN	C	1.062	1.060	54	----	PLT
4114A	B	1.437	.615	7SS	----	.406	1119	C	1.062	1.025	1C	1.250	.406
4290A	B	1.437	.615	11CS	----	.375	1119V	C	1.062	.968/1.093	1	1.250	.406
4660A	B	1.437	.615	3SS	1.180	.250	1124AE	C	1.062	.875	1C	1.375	.406
5940A	B	1.437	.615	7C	----	.406	1124AV	C	1.062	.875	1C	1.375	.406
6005	B	1.437	.615	1B	1.187	.172	1125AN	C	1.062	.812	1SS	1.062	.312
6860	B	1.437	.622	2	1.250	.390	1140A	C	1.062	.980	1SS	1.000	.297
7813YBO	B	1.437	----	1	1.207	----	1145A	C	1.062	.875	1SS	1.125	.406
9904A	B	1.437	.615	1SS	1.187	.172	1154	C	1.062	.875	1SS	1.187	.343
9928A	B	1.437	.615	1C	1.250	.343	1155	C	1.062	.875	1C	1.187	.288
10004	B	1.437	.615	1SS	----	.215	1155V	C	1.062	.875	1C	1.187	.288
10050A	B	1.437	.615	1C	1.375	.280	1155VTC	C	1.062	.875	1	1.187	.288
10050AV	B	1.437	.615	1C	1.375	.280	1156	C	1.062	.875	1C	1.250	.406
10051A	B	1.437	.615	1SS	1.375	.280	1156V	C	1.062	.875	1	1.250	.406
0611X	B	1.437	.615	1C	1.078	.210	1165A	C	1.062	.690	1SS	1.125	.406
0613X	B	1.437	.615	6SS	----	.225	1170AN	C	1.062	.875	51	----	PLT
							1215AN	C	1.062	.937	----	----	----
							1216AN	C	1.062	.937	1B	1.125	.125
							1218A	C	1.062	.937	1C	1.145	.312
							1220AN	C	1.062	.875	1SS	1.125	.250
104	C	1.062	.875	3B	1.000	.470	1230A	C	1.062	1.060	----	----	----
110	C	1.062	.812	5SS	1.125	.500	1230AV	C	1.062	1.060	----	----	----
118	C	1.062	.812	1C	1.187	.343	1233A	C	1.062	.937	1C	1.141	.312
181N	C	1.062	.843	50	----	PLT	1250AN	C	1.062	.750	1C	1.312	.312
222	C	1.062	.875	3SS	1.125	.500	1252AV	C	1.062	.725	1C	1.250	.406
290	C	1.062	.875	1C	1.250	.406	1260AN	C	1.062	.812	50	1.188	PLT
290V	C	1.062	.875	1C	1.250	.406	1260AV	C	1.062	.812	50	1.188	PLT
359	C	1.062	.875	1C	1.250	.406	1505	C	1.062	.875	1C	1.312	.250
359V	C	1.062	.875	1C	1.250	.406	1618	C	1.062*	.937	1C	1.250	.406
359VHD	C	1.062	.875	3	1.250	.406	1625	C	1.062	.609	3SS	1.250	.406
493	C	1.062	.875	1SS	1.187	.288	1626V	C	1.062	.609	3SS	1.250	.406
536	C	1.062	.875	3C	1.187	.343	1810A	C	1.062	.973	50	1.125	PLT
552	C	1.062	.875	3C	1.250	.875	2135AN	C	1.062	.812	54B	----	PLT
552E	C	1.062	.875	3	1.250	.406	2149	C	1.062*	.937	3SS	1.250	.406
626V	C	1.187	SLEEVE	1C	1.375	.406	2160	C	1.062	.718	1C	1.250	.406
633	C	1.062	.875	1SS	1.250	.406	2175AN	C	1.062	.937	54	----	PLT
633V	C	1.062	.875	3SS	1.250	.406	2206	C	1.062	.812	3	1.250	.406
633VHD	C	1.062	.875	1	1.250	.406	2214	C	1.062	.875	1	1.187	.296
732	C	1.062	.875	3SS	1.250	.406	2390AN	C	1.062	.812	54	----	PLT
732E	C	1.062	.875	3SS	1.250	.406	3230AN	C	1.062	.780	51	----	PLT
733	C	1.062	.875	3C	1.187	.288	3525	C	1.062	.875	3	1.250	.375
800	C	1.062	.875	1C	1.156	.312	3707	C	1.048	.859	1	1.187	.296
810N	C	1.062*	.765	1C	1.250	.406	3910A	C	1.062	.812	51	.995	PLT
869	C	1.062	.875	3C	1.448	.265	4156AN	C	1.062	1.050	51	----	PLT
900	C	1.062	.812	2B	1.187	.312	4215AN	C	1.062	1.050	52	----	PLT
901	C	1.062	.812	8B	1.187	.312	4305A	C	1.062	.700	1C	1.250	.250
933	C	1.062	.875	----	----	----	4460AN	C	1.062	.937	1C	1.250	.406
933V	C	1.062	.875	----	----	----	4535AN	C	1.062	.770	1C	1.150	.312
951V	C	1.062	.875	3SS	1.375	.406	4670A	C	1.062	.690	1C	1.188	.219
970	C	1.062	.875	2B	1.312	.312	5160A	C	1.062	.875	1SS	1.437	.250
980	C	1.062	.875	1C	1.250	.406	5235A	C	1.062	.720	1C	1.250	.343
989N	C	1.062*	.765	1C	1.187	.288	5235AV	C	1.062	.720	1C	1.250	.343
990N	C	1.062	.765	2B	1.312	.312	6216	C	1.062	.875	1	1.250	.406
1016	C	1.062*	.765	1C	1.187	.343	6234	C	1.062	.609	1	1.250	.406
1027	C	1.062	.906	1SS	1.141	.312	6340A	C	1.062	.437	----	----	----
1045U	C	1.062	.718	3C	1.250	.406	7547	C	1.062	.875	1	1.250	.406
1066	C	1.062	.875	3C	1.250	.406	7840AN	C	1.062	.875	1B	1.000	.437
1079N	C	1.062	.875	1C	1.250	.406	8500AN	C	1.062	1.000	1C	1.250	.406
1080N	C	1.062	.875	1C	1.250	.406	9001AN	C	1.062	.875	1SS	1.187	.343
1085V	C	1.062*	.937	1C	1.250	.406	9075A	C	1.062	1.000	----	----	----
1091V	C	1.062	.715	1C	1.187	.343	9220A	C	1.062	.770	1SS	1.141	.312
							0606XE	C	1.062	.750	3SS	1.187	.343
							0611XP	C	1.062	.875	1C	1.250	.406
							0688XV	C	1.062	.875	3SS	1.250	.312
							06145X	C	1.062*	.687	----	----	----
							06164XN	C	1.062*	.765	----	----	----
							061674X	C	1.062*	.875	1SS	1.250	.406
							15-52	C	1.062	.812	1C	1.175	.375

Part No.	Type	O.D.	OP. Height	Type	C' Bore	Thk.	Part No.	Type	O.D.	OP. Height	Type	C' Bore	Thk.
.625 SHAFT							.625 SHAFT						
ROTARY				SEAT			ROTARY				SEAT		
1100A	C-S	1.062	.937	3B	1.000	.656	2016	E	1.093	1.312	1C	1.250	.406
1108A	C-S	1.062	.937	----	----	----	2017	E	1.093	1.312	1SS	1.250	.406
1135A	C-S	1.062	.937	----	----	----	2018	E	1.093	1.312	3C	1.250	.406
4212AN	C-S	1.062	.770	51	----	PT	2019	E	1.093	1.312	3SS	1.250	.406
							2020	E	1.093	1.312	1C	1.187	.343
							2021	E	1.093	1.312	1SS	1.187	.343
							2022	E	1.093	1.312	3C	1.187	.343
							2023	E	1.093	1.312	3SS	1.187	.288
							8000AN	E	1.093	1.312	1C	1.150	.312
							9710A	E	1.093	1.312	1C	1.187	.343
102	D	1.312	.875	1SS	1.250	.406	06163X	E	1.093	1.312	----	----	----
102V	D	1.312	.875	3SS	1.250	.406							
109	D	1.312	.875	----	----	----							
226	D	1.312	.875	1SS	1.187	.288	626V	G	1.062	.875	1C	1.375	.406
263	D	1.312	.875	1SS	1.187	.343							
508	D	1.312	.875	1C	1.250	.406							
508V	D	1.312	.875	3C	1.250	.406	678	K	1.062	1.187	----	----	----
531	D	1.312	.875	1C	1.187	.288	863N	K	1.062	1.187	----	----	----
734	D	1.312	.875	3SS	1.250	.406	8630A	K	1.062	1.287	----	----	----
735	D	1.312	.875	3C	1.250	.406	8631A	K	1.062	1.287	51B	----	PLT
736	D	1.312	.875	3C	1.187	.288	06166X	K	1.062	1.187	1C	1.250	.406
737	D	1.312	.875	3C	1.141	.343	06167X	K	1.062	1.187	1SS	1.250	.406
922	D	1.312	.875	1SS	1.250	.312	06168X	K	1.062	1.187	3C	1.250	.406
1157	D	1.312	.875	2SS	1.250	.343	06169X	K	1.062	1.187	3SS	1.250	.406
2000	D	1.312	.875	1C	1.250	.406							
2001	D	1.312	.875	1SS	1.250	.406	1318AN	L-1	1.000	1.625	----	----	----
2002	D	1.312	.875	3C	1.250	.406	5965AV	L-1	1.000	.812	----	----	----
2003	D	1.312	.875	3SS	1.250	.406							
2004	D	1.312	.875	1C	1.187	.343							
2005	D	1.312	.875	1SS	1.187	.343	1150AN	L-2	1.000	1.250	----	----	----
2006	D	1.312	.875	3C	1.187	.343	8300A	L-2	1.000	1.500	----	----	----
2007	D	1.312	.875	1SS	1.187	.288							
2119	D	1.312	.875	1C	1.187	.288							
4210AN	D	1.312	.875	51	----	PLT	0604X	Q	1.500	.556	1C	1.187	.343
4245A	D	1.312	.925	1C	1.250	.406	0606X	Q	1.500	.556	----	----	----
4245AV	D	1.312	.925	1C	1.250	.406							
5150A	D	1.312	.875	1C	1.187	.338							
							4420A	R	1.312	1.625	1C	1.875	.437
5590AN	D-B	1.312	.775	8B	THREADED	.203							
							795N	S	1.312	1.395	8SS	1.187	.125
							3920AN	S	1.263	1.310	8SS	M.O.S.	.125
							3960A	S	1.200	1.180	8SS	M.O.S.	.125
274	E	1.093	1.312	1C	1.250	.406							
274V	E	1.093	1.312	1	1.250	.406							
485	E	1.093	1.312	1C	1.187	.343	1155AN	T	1.093	1.400	----	----	----
486	E	1.093	1.312	1SS	1.187	.288	06165X	T	1.093	1.625	----	----	----
487	E	1.093	1.312	1SS	1.250	.406	06170X	T	1.093	1.625	1C	1.250	.406
738	E	1.093	1.312	3SS	1.250	.406	06171X	T	1.093	1.625	1SS	1.250	.406
739	E	1.093	1.312	3C	1.250	.406	06172X	T	1.093	1.625	3C	1.250	.406
740	E	1.093	1.312	3C	1.187	.288	06173X	T	1.093	1.625	3SS	1.250	.406
748	E	1.093	1.312	3C	1.187	.343							
1158	E	1.093	1.312	2SS	1.250	.343							
1210AN	E	1.093	1.110	1SS	1.250	.406							
1210AV	E	1.093	1.110	1SS	1.250	.406							
1689	E	1.093	1.312	1SS	1.187	.343							





Part No.	Type	O.D.	OP. Height	Type	C' Bore	Thk.	Part No.	Type	O.D.	OP. Height	Type	C' Bore	Thk.	
<b>.780 SHAFT</b>							<b>.875 SHAFT</b>							
<b>ROTARY</b>				<b>SEAT</b>			<b>ROTARY</b>				<b>SEAT</b>			
1665A	G	1.187	1.000	51	1.937	PLT	144	D	1.562	.937	3SS	1.625	.406	
							250	D	1.562	.937	3SS	1.500	.406	
							303	D	1.562	.937	1SS	1.500	.406	
							303V	D	1.562	.937	3	1.500	.406	
<b>.787 SHAFT (20MM)</b>							578	D	1.562	.937	----	----	----	
135	D	1.562	.937	1C	1.500	.406	602	D	1.562	.937	1C	1.562	.406	
139	D	1.562	1.218	17SS	1.296	.468	603	D	1.562	.937	2SS	1.562	.406	
614	D	1.562	.937	1S	1.500	.406	703	D	1.562	.937	1C	1.500	.406	
614V	D	1.562	.937	3	1.500	.406	703V	D	1.562	.937	3	1.500	.406	
							775	D	1.562	.937	3C	1.500	.406	
							790	D	1.562	.921	1C	1.437	.265	
1560A	L-1	1.187	NO SPRING	----	----	----	1127N	D	1.562	.875	3SS	1.490	.406	
							1681	D	1.562	.937	3SS	1.437	.265	
							1741A	D	1.562	.937	2SS	1.500	.437	
							2024	D	1.562	.937	1C	1.500	.406	
<b>.812 SHAFT</b>							2025	D	1.562	.937	1SS	1.500	.406	
1570A	C	1.281	.812	51	1.625	PLT	2026	D	1.562	.937	3C	1.500	.406	
1575A	C	1.281	1.100	2SS	1.312	.312	2027	D	1.562	.937	3SS	1.500	.406	
4196A	C	1.281	.937	51	----	PLT	2027V	D	1.562	.937	3	1.500	.406	
4355A	C	1.281	1.100	54	----	PLT	5320A	D	1.562	.937	3SS	1.437	.250	
<b>.848 SHAFT</b>														
1580A	M	1.750	1.275	3SS	1.218	.453								
<b>22 MM SHAFT</b>							188	E	1.343	1.375	1C	1.500	.406	
							188V	E	1.406	1.375	3	1.500	.406	
50086	C	1.281	.937	1C	38MM	.406	229	E	1.343	1.375	3SS	1.500	.406	
							776	E	1.343	1.375	3C	1.500	.406	
							935	E	1.343	1.375	1SS	1.500	.406	
<b>.875 SHAFT</b>							936	E	1.343	1.375	----	----	----	
208	C	1.281	.937	----	----	----	997	E	1.343	1.375	3C	1.625	.406	
294	C	1.281	.937	2SS	1.562	.406	998	E	1.343	1.375	3SS	1.625	.406	
309	C	1.281	.937	1C	1.500	.406	2028	E	1.343	1.375	1C	1.500	.406	
309V	C	1.312	.937	1	1.500	.406	2029	E	1.343	1.375	1SS	1.500	.406	
617	C	1.281	.937	3SS	1.500	.406	2030	E	1.343	1.375	3C	1.500	.406	
687	C	1.281	.937	1SS	1.500	.406	2031	E	1.343	1.375	3SS	1.500	.406	
687V	C	1.312	.937	1	1.500	.406	7859	E	1.406	1.375	3	1.312	.406	
774	C	1.281	.937	3C	1.500	.406	7896	E	1.406	1.375	3	1.500	.406	
875LS	C	1.281	1.375	1C	1.500	.406	7915AN	E	1.343	1.375	51	----	PLT	
1051V	C	1.281	.937	3C	1.500	.406								
1116	C	1.281	.812	3C	1.875	.390								
1163	C	1.281	.937	1SS	1.562	.406								
1605AN	C	1.281	.825	----	----	----	3436A	F	1.546	.575	3SS	1.625	.375	
1610AN	C	1.281	.937	2SS	1.250	.375	3450A	F	1.546	.475	53	----	PLT	
1636AV	C	1.281	.700	1C	1.500	.187	3451A	F	1.500	.450	53	----	PLT	
1645AN	C	1.281	.600	----	----	----	3452A	F	1.500	.450	53	----	PLT	
1685AN	C	1.281	1.100	51	1.875	PLT	3453A	F	1.546	.475	53	----	PLT	
1690AN	C	1.281	.937	3SS	1.312	.421	3455A	F	1.546	.475	52	----	PLT	
1710AN	C	1.281	.650	2B	1.500	.312	3456A	F	1.500	.475	53	----	PLT	
1715AN	C	1.281	.825	2SS	1.500	.406								
1720AN	C	1.281	.937	2B	1.437	.406								
1732AN	C	1.281	.875	1TC	1.500	.406								
1794AN	C	1.281	1.100	3SS	1.500	.406								
2166	C	1.312	.937	1	1.437	.265	287	J	1.350	.875	1C	1.500	.375	
2166E	C	1.312	.937	1	1.437	.265								
2167	C	1.312	.812	1	1.500	.406								
2168	C	1.312	.937	3	1.437	.265								
2169	C	1.312	.812	3	1.437	.265								
2169V	C	1.312	.812	3	1.437	.265								
2224	C	1.312	.812	3	1.437	.265	197	K	1.281	1.250	----	----	----	
3749	C	1.312	.812	1	1.500	.218	878	K	1.281	1.250	1SS	1.500	.406	
3907	C	1.312	.781	1	1.500	.406	892	K	1.281	1.250	1C	1.500	.406	
3996	C	1.312	.919	1	1.500	.406	892V	K	1.281	1.250	3	1.500	.406	
4120AN	C	1.281	.812	54	----	PLT	1099	K	1.281	1.250	1C	1.500	.406	
4157AN	C	1.281	.937	54	----	PLT	4205A	K	1.281	1.250	51	----	PLT	
4368AN	C	1.281	1.250	51	1.875	PLT								
4369AN	C	1.281	1.250	51	1.875	PLT								
5136AN	C	1.281	.937	52	----	PLT								
6345AN	C	1.281	.937	54	----	PLT								
6435AN	C	1.281	.812	55	----	PLT								
7130	C	1.312	.812	1	1.500	.406								
7990AN	C	1.281	.937	1SS	1.375	.312								

Part No.	Type	O.D.	OP. Height	Type	C' Bore	Thk.	Part No.	Type	O.D.	OP. Height	Type	C' Bore	Thk.
<b>.875 SHAFT</b>							<b>.984 SHAFT (25MM)</b>						
<b>ROTARY</b>				<b>SEAT</b>			<b>ROTARY</b>				<b>SEAT</b>		
1705A	L-2	1.375	1.050	----	----	----	20-52	C	1.687	1.000	1C	1.750	.406
4794A	L-2	1.437	1.250	25CA	1.525	.514	21-52	C	1.687	1.000	1C	1.750	.406
140	R	1.562	1.625	----	----	----	1785AN	C	1.687	.843	----	----	----
428	R	1.562	1.625	1C	1.500	.406	1790AN	C	1.687	.843	3SS	1.500	.375
685	R	1.562	1.625	1SS	1.500	.406	7815YB1	C	1.687	----	SP	----	----
10003	SP	SP	.937	----	----	----	25SCSC	K	1.687	1.250	2SC	44MM	.406
6940A	U	1.312	1.500	3SS	1.375	.406	2900AN	L-1	1.688	1.375	3B	1.625	.500
<b>.937 SHAFT</b>							<b>1.000 SHAFT</b>						
1755A	C	1.687	1.000	1B	1.750	.437	360	A	1.687	.812	1C	1.625	.437
1760A	C	1.687	.843	1SS	1.750	.344	360V	A	1.687	.812	1	1.625	.437
1765A	C	1.594	.843	3SS	2.050	.469	370	A	1.687	.812	1SS	1.625	.437
1770AN	C	1.687	.843	1SS	1.750	.344	405	A	1.687	.812	15C	1.625	.625
1780A	C	1.687	1.375	1SS	1.750	.437	640	A	1.687	.812	SPEC	----	.187
5110AN	C	1.687	1.000	52	----	PLT	777	A	1.687	.812	3C	1.625	.437
5197AN	C	1.687	1.000	51	----	PLT	778	A	1.687	.812	3SS	1.625	.437
9460A	C	1.687	.750	8SS	1.750	.234	975	A	1.687	.812	----	----	----
9444AN	D	2.375	1.625	7SS	M.O.S.	.437	1014V	A	1.687	.812	1C	1.625	.437
9470A	F	1.625	.625	8SS	1.750	.234	1086	A	1.687	.812	3C	2.000	.406
1775AN	L-1	1.594	.600	----	----	----	1086V	A	1.687	.812	3	2.000	.406
527	U	1.437	1.656	2C	1.562	.406	1115	A	1.687	.812	1C	1.625	.437
560	U	1.437	1.656	2SS	1.562	.406	1164	A	1.687	.812	1SS	1.625	.437
560SS	U	1.437	1.656	2SS	1.562	.406	5630A	A	1.687	.812	3SS	1.625	.437
823	U	1.437	1.656	3SS	1.562	.406	5630AV	A	1.687	.812	3SS	1.625	.437
824	U	1.437	1.656	3C	1.562	.406	1619	B	1.625	.874	1C	1.625	.437
845	U	1.437	1.656	3SS	1.562	.406	1806A	B	1.875	.812	1C	1.625	.437
3275AN	C	1.687	1.000	2B	1.625	.375	19180A	B	1.875	1.000	----	----	----
6357AN	C	1.687	1.250	51	2.000	PLT	235	C	1.687	1.000	1C	1.625	.437
235V	C	1.687	1.000	1	1.625	.437	245*	C	1.687	1.000	1C	1.625	.437
245V	C	1.687	1.000	1	1.625	.437	245E	C	1.687	1.000	1	1.625	.437
245E	C	1.687	1.000	1	1.625	.437	248*	C	1.687	1.000	1SS	1.625	.437
248*	C	1.687	1.000	1SS	1.625	.437	248V	C	1.687	1.000	1	1.625	.437
248V	C	1.687	1.000	1	1.625	.437	248E	C	1.687	1.000	1	1.625	.437
248E	C	1.687	1.000	1	1.625	.437	311*	C	1.687	1.062	18C	1.700	.370
311*	C	1.687	1.062	18C	1.700	.370	357	C	1.687	1.000	1SS	1.625	.437
357	C	1.687	1.000	1SS	1.625	.437	357V	C	1.687	1.000	1	1.625	.437
357V	C	1.687	1.000	1	1.625	.437	397	C	1.687	1.000	----	----	----
397	C	1.687	1.000	----	----	----	397V	C	1.687	1.000	----	----	----
397V	C	1.687	1.000	----	----	----	413	C	1.687	1.000	15C	1.625	.625
413	C	1.687	1.000	15C	1.625	.625	499	C	1.687	1.000	3SS	1.625	.437
499	C	1.687	1.000	3SS	1.625	.437	499E	C	1.687	1.000	3	1.625	.437
499E	C	1.687	1.000	3	1.625	.437	539	C	1.437	1.625	1C	1.625	.437
539	C	1.437	1.625	1C	1.625	.437	548	C	1.687	1.000	3C	1.625	.437
548	C	1.687	1.000	3C	1.625	.437	779	C	1.437	1.625	1SS	1.625	.437
779	C	1.437	1.625	1SS	1.625	.437	982	C	1.687	1.562	1SS	1.625	.437
982	C	1.687	1.562	1SS	1.625	.437	1023	C	1.687	1.056	1C	1.625	.437
1023	C	1.687	1.056	1C	1.625	.437	1034	C	1.687	1.000	28	2.440	.438
1034	C	1.687	1.000	28	2.440	.438	1048	C	1.437	.750	1C	1.625	.437
1048	C	1.437	.750	1C	1.625	.437	1049	C	1.687	.750	3C	1.625	.437
1049	C	1.687	.750	3C	1.625	.437	1072	C	1.687	1.015	3C	1.812	.687
1072	C	1.687	1.015	3C	1.812	.687	1094V	C	1.687	.812	1C	1.625	.437
1094V	C	1.687	.812	1C	1.625	.437	1095	C	1.687	.812	----	----	----
1095	C	1.687	.812	----	----	----	1117	C	1.687	.812	3C	2.380	.406
1117	C	1.687	.812	3C	2.380	.406	1123	C	1.687	.843	1SS	1.625	.406
1123	C	1.687	.843	1SS	1.625	.406	1126	C	1.687	1.000	1C	1.625	.406
1126	C	1.687	1.000	1C	1.625	.406	1827A	C	1.437	1.625	1C	1.500	.375
1827A	C	1.437	1.625	1C	1.500	.375							

Part No.	Type	O.D.	OP. Height	Type	C' Bore	Thk.	Part No.	Type	O.D.	OP. Height	Type	C' Bore	Thk.
1.000 SHAFT							1.000 SHAFT						
ROTARY				SEAT			ROTARY				SEAT		
1838AV	C	1.687	.843	1TC	1.625	.437	1890A	E	1.500	1.187	2B	1.812	.437
1868AN	C	1.687	.843	1SS	1.625	.437	1905A	E	1.500	1.000	1SS	1.625	.437
1875AN	C	1.687	1.000	51	----	PLT	1905AV	E	1.500	1.000	1SS	1.625	.437
1880AN	C	1.687	1.625	51	----	PLT	1985AN	E	1.500	1.000	2B	1.687	.344
1906A	C	1.687	.843	1C	1.625	.437	1995AN	E	1.500	1.000	2B	1.875	.375
1925AN	C	1.687	1.000	51	2.125	PLT	2035	E	1.500	1.562	1C	1.625	.437
2069AV	C	1.687	.843	3SS	1.937	.563	2036	E	1.500	1.562	1SS	1.625	.437
2145	C	1.687	1.000	3	1.437	.437	2065A	E	1.500	.875	1C	1.625	.437
2163	C	1.687	1.625	1	1.750	.437	2070AN	E	1.500	1.000	52	2.500	PLT
2216	C	1.687	1.000	1	1.625	.437	2075A	E	1.500	1.000	2C	1.875	.437
2216V	C	1.687	1.000	1	1.625	.437	2080AN	E	1.500	1.000	2B	2.062	.282
3440	C	1.687	1.000	1C	1.750	.437	2095AN	E	1.500	1.000	51/1	1.937	PLT
3755	C	1.687	1.000	3	1.437	.437	4810AN	E	1.500	1.000	2SS	1.625	.344
3824	C	1.687	1.000	1	1.625	.437	4911AV	E	1.500	1.000	1C	1.625	.437
4081	C	1.671	1.062	1	1.625	.375	5785A	E	1.500	1.000	1C	1.750	.437
4515A	C	1.437	1.625	1C	1.750	.437	5785AV	E	1.500	1.000	1C	1.750	.437
5170AV	C	1.687	1.562	1SS	1.625	.437	7540A	E	1.500	1.562	1C	1.625	.437
6161AN	C	1.687	1.500	51	----	PLT	7540AV	E	1.500	1.562	1C	1.625	.437
6288AN	C	1.687	1.300	52	----	PLT							
6430AN	C	1.687	1.000	52	----	PLT							
9158AN	C	1.687	1.562	52	----	PLT							
9178AN	C	1.687	1.000	52	----	PLT							
9179AN	C	1.687	1.625	52	----	PLT	813	J	1.470	1.000	1C	1.625	.375
9420AN	C	1.687	1.375	52	----	PLT							
10005SCSC	C	1.687	1.000	1SC	1.875	.437							
159N	D	1.750	1.000	3SS	1.625	.437							
227	D	1.750	1.062	1SS	1.750	.437							
252	D	1.750	1.062	3SS	1.625	.437	879	K	1.687	1.625	1C	1.625	.437
252E	D	1.812	1.062	3	1.625	.437	891	K	1.687	1.625	1SS	1.625	.437
380	D	1.750	1.062	1C	1.625	.437	4850AN	K	1.687	1.875	3SS	1.875	.500
380V	D	1.812	1.000	1	1.625	.437	9907AN	K	1.687	1.625	52/2	1.250	.359
398	D	1.750	1.062	----	----	----							
438	D	1.750	1.062	18C	1.700	.370							
460	D	1.750	1.062	1SS	1.625	.437							
460V	D	1.812	1.062	1	1.625	.437							
460TCSC	D	1.750	1.062	1SC	1.625	.437	1945AN	L-1	1.812	.625	----	----	----
789	D	1.750	1.062	3C	1.625	.437	2015AN	L-1	1.625	1.000	----	----	----
987	D	1.750	1.062	3C	1.875	.437	2030AN	L-1	1.750	NO SPRING	1CA	1.750	.390
1046	D	1.750	1.062	1C	1.625	.437	3940AN	L-1	1.500	.375	8B	1.375	.175
1138	D	1.750	1.000	3C	1.625	.437	4830AN	L-1	1.562	1.250	----	----	----
1630	D	1.750	1.000	3SS	1.625	.312							
1630V	D	1.812	1.000	3	1.625	.312							
1940AN	D	1.750	1.375	3SS	1.625	.312							
2032	D	1.750	1.062	1C	1.625	.437	2060AN	L-2	1.625	1.500	----	----	----
2033	D	1.750	1.062	3C	1.625	.437	3922AN	L-2	1.875 BORE	1.875	8SS	M.O.S.	.350
2034	D	1.750	1.062	3SS	1.625	.437	3965A	L-2	1.750 BORE	1.475	8SS	M.O.S.	.187
2164	D	1.750	1.062	1C	1.750	.437	7905AN	L-2	1.625	2.475	----	----	----
3900	D	1.812	1.000	1	1.625	.437							
7991	D	1.812	1.000	25	1.625	.500							
236	E	1.500	1.562	1SS	1.625	.437	3100	N	Spc.Uni.				
236V	E	1.500	1.562	1	1.625	.437	3401	N	1.906	.471	9	----	.421
251	E	1.500	1.187	3SS	1.625	.437							
557	E	1.500	1.562	3C	1.625	.437							
695	E	1.500	1.562	2SS	1.625	.406	141	R	1.750	1.875	----	----	----
696N	E	1.500	1.562	PLATE	23		429	R	1.750	1.875	1C	1.625	.437
754	E	1.500	1.562	1C	1.625	.437	430	R	1.750	1.875	1SS	1.625	.437
754V	E	1.500	1.562	1	1.625	.437	1022	R	1.750	1.875	3C	1.625	.437
791	E	1.500	1.562	3SS	1.625	.437							
912	E	1.500	1.562	1C	1.500	.437							
937	E	1.500	1.562	----	----	----							
937V	E	1.500	1.562	----	----	----							
1030V	E	1.500	1.562	3SS	1.625	.437	793	S	1.904	1.906	8SS	1.750	.250
1165	E	1.500	1.562	3C	1.625	.437							
1166	E	1.500	1.562	3SS	1.625	.437	1826AN	SP	1.925	.500	7SS	M.O.S.	.360
1815AN	E	1.500	1.187	----	----	----							
1832AV	E	1.500	1.000	1C	1.625	.437							
1855AN	E	1.500	1.000	3SS	2.000	.500							
1857SCAV	E	1.500	1.000	3SC	1.625	.437							
1860AN	E	1.500	1.000	2SS	1.750	.250							



Part No.	Type	O.D.	OP. Height	Type	C' Bore	Thk.	Part No.	Type	O.D.	OP. Height	Type	C' Bore	Thk.
<b>1.000 SHAFT</b>							<b>1.125 SHAFT</b>						
<b>ROTARY</b>				<b>SEAT</b>			<b>ROTARY</b>				<b>SEAT</b>		
276	T	1.500	2.312	1C	1.625	.437	529	C	1.812	1.062	3SS	1.750	.437
277	T	1.500	2.312	1SS	1.625	.437	529E	C	1.812	1.062	3	1.750	.437
688	T	1.500	2.250	3C	1.625	.437	549	C	1.812	1.062	25C	1.750	.437
1631N	T	1.500	1.968	3SS	1.625	.312	588*	C	1.812	1.062	3SS	1.750	.437
1631VSS	T	1.500	2.312	3TC	1.625/1.687	.437	627*	C	1.812	1.406	1C	1.750	.437
1845AN	T	1.500	1.600	5I	2.000	PLT	801	C	1.812	1.062	3C	1.750	.437
1850AN	T	1.500	1.600	----	----	----	983	C	1.812	1.562	1SS	1.750	.437
1851AN	T	1.500	1.600	8SS	1.690	.190	983V	C	1.812	1.562	3	1.750	.437
2115AN	T	1.500	2.000	1C	1.625	.875	1014AN	C	1.812	.700	52/1	2.062	PLT
2115AV	T	1.500	2.000	1C	1.625	.875	1052	C	1.812	1.062	1C	1.750	.437
3070AN	T	1.500	1.600	5I	----	PLT	1122	C	1.812	1.500	1C	1.937	.437
3912A	T	1.500	1.875	5I	1.625	PLT	1125SCSC	C	1.625	1.062	1SC	1.750	.437
3975A	T	1.500	1.500	2SS	2.000	.437	1125SCTC	C	1.625	1.062	1TC	1.750	.437
4015AN	T	1.500	1.600	5I	----	PLT	1143	C	1.812	1.062	3SS	1.750	.437
							1167*	C	1.812	1.062	1SS	1.750	.437
							1332A	C	1.812	1.062	5I	----	PLT
							1682*	C	1.812	1.062	1C	1.750	.437
<b>1.040 SHAFT</b>							2185AN	C	1.812	1.062	3SS	1.625	.500
2145AN	C	1.687	1.062	5I	----	PLT	2185AV	C	1.812	1.062	3SS	1.625	.500
9291AN	C	1.687	1.062	5I	----	PLT	2187A	C	1.812	1.062	8SS	----	PLT
							2205AN	C	1.812	1.062	----	----	----
							2226	C	1.812	1.062	3	1.750	.437
							2227	C	1.812	1.562	1	1.750	.437
							2240AN	C	1.812	1.500	5I	1.875	PLT
<b>1.062 SHAFT (27MM)</b>							2250A	C	1.812	1.000	5I	2.250	PLT
1407A	C	1.687	.750	5I	----	PLT	2255AN	C	1.812	1.562	2SS	1.750	.375
2140A	C	1.687	1.062	2SS	1.750	.437	2260A	C	1.812	1.062	52	----	PLT
2155	C	1.812	1.062	3SS	1.750	.437	2261A	C	1.812	1.062	3SS	2.843	.375
2155A	C	1.687	1.062	2SS	1.812	.312	2270AN	C	1.812	2.375	5I	2.562	PLT
2160AN	C	1.687	1.062	----	----	----	2280AN	C	1.812	1.500	5I	2.562	PLT
5330A	C	1.687	.750	52	----	PLT	2285AN	C	1.812	1.500	2SS	2.000	.500
							2285AV	C	1.812	1.500	2SS	2.000	.500
							2350A	C	1.812	1.062	2SS	2.000	.500
127	D	1.875	1.062	1SS	1.750	.437	2386AV	C	1.812	1.062	1TC	1.750	.437
796	D	1.875	1.062	3SS	1.750	.437	7920AN	C	1.812	1.562	5I	----	PLT
797	D	1.875	1.062	3C	1.750	.437	9375AN	C	1.812	1.562	5I	----	PLT
							9376AN	C	1.812	2.500	52	----	PLT
498	E	1.625	1.593	1SS	1.750	.437	254	D	1.875	1.062	3SS	1.750	.437
710	E	1.625	1.593	1C	1.750	.437	344	D	1.875	1.062	1C	1.750	.437
798	E	1.625	1.593	3C	1.750	.437	521	D	1.875	1.062	2SS	1.875	.562
799	E	1.625	1.593	3SS	1.750	.437	604	D	1.875	1.062	1C	1.750	.437
							604E	D	1.875	1.062	1	1.750	.437
							605	D	1.875	1.062	1SS	1.750	.437
							605V	D	1.875	1.062	3	1.750	.437
							613	D	1.875	1.062	1SS	1.750	.437
2162AV	L-1	1.500	1.175	----	----	----	802	D	1.875	1.062	3C	1.750	.437
6694AN	L-1	2.000	1.375	----	----	----	1131	D	1.875	1.062	1C	1.750	.437
							1140	D	1.875	1.062	3C	1.750	.437
							2037	D	1.875	1.062	1C	1.750	.437
1946AV	Z	2.125	.950	SEATS UNITIZED WITH SEAL			2038	D	1.875	1.062	1SS	1.750	.437
							2039	D	1.875	1.062	3C	1.750	.437
							2040	D	1.875	1.062	3SS	1.750	.437
							5116A	D	1.875	1.575	50	1.922	PLT
<b>1.083 SHAFT</b>													
2093A	C	1.812	1.062	2B	1.937	.437	204	E	1.625	1.625	1C	1.750	.437
2165A	C	1.812	1.062	2B	1.937	.437	204V	E	1.625	1.625	3	1.750	.437
							253	E	1.625	1.187	3SS	1.750	.437
							384	E	1.625	1.625	1SS	1.750	.437
<b>1.125 SHAFT</b>							584	E	1.625	1.625	3C	1.750	.437
348	C	1.812	1.062	----	----	----	607	E	1.625	1.625	1C	1.687	.437
348V	C	1.812	1.062	----	----	----	608	E	1.625	1.625	1SS	1.687	.437
355	C	1.812	1.062	1SS	1.750	.437	619	E	1.625	2.000	3C	1.812	.437
355V	C	1.812	1.062	1	1.750	.437	636	E	1.625	2.000	3SS	1.812	.437
355HD	C	1.812	1.062	1	1.750	.437							
355SCSC	C	1.812	1.062	1	1.750	.437							
356	C	1.812	1.062	1C	1.750	.437							
356E	C	1.812	1.062	1	1.750	.437							
356V	C	1.812	1.062	1	1.750	.437							
356VSCSC	C	1.812	1.062	1	1.750	.437							

Part No.	Type	O.D.	OP. Height	Type	C' Bore	Thk.	Part No.	Type	O.D.	OP. Height	Type	C' Bore	Thk.
1.125 SHAFT							1.125 SHAFT						
ROTARY				SEAT			ROTARY				SEAT		
866	E	1.625	1.937	3C	1.750	.437	4796A	L-2	1.625	1.000	25CA	1.770	.625
867	E	1.625	1.937	3SS	1.750	.437	6845AN	L-2	1.750	2.750	51	2.125	PLT
867V	E	1.625	1.625	3	1.750	.437							
867E	E	1.625	1.625	1	1.750	.437							
867TCTC	E	1.625	1.937	3TC	1.750	.437							
885	E	1.625	1.625	3SS	1.750	.437							
945	E	1.625	2.000	3C	1.812	.437	654	R	1.875	1.875	1SS	1.750	.437
948	E	1.625	2.000	3SS	1.812	.437	676	R	1.875	1.875	1C	1.750	.437
1067	E	1.625	1.625	2SS	1.875	.521							
1139	E	1.625	2.031	3C	1.750	.437							
1168	E	1.625	1.625	1SS	1.750	.437	9T-1125	9T	SPEC*	SPEC*	2SS	2.000	.437
1169	E	1.625	1.625	1C	1.750	.437							
1170	E	1.625	1.625	1C	1.687	.437							
1171	E	1.625	1.625	1SS	1.687	.437	886	T	1.625	2.375	3C	1.750	.437
1172	E	1.625	1.937	3C	1.812	.437	918	T	1.625	2.375	3SS	1.750	.437
1172V	E	1.625	1.625	3	1.812	.437	1178	T	1.625	2.375	3C	1.812	.437
1173	E	1.625	1.937	3SS	1.812	.437	3511	T	1.625	2.125	3	1.750	.437
1174	E	1.625	1.625	1C	1.750	.437	3976AN	T	1.625	1.625	2C	2.125	.437
1175	E	1.625	1.625	1SS	1.750	.437	9055A	T	1.625	2.000	1C	1.750	.437
1330A	E	1.625	1.000	1C	1.750	.437							
1330AV	E	1.625	1.000	1C	1.750	.437							
1331A	E	1.625	1.000	1SS	1.750	.437							
1331AV	E	1.625	1.000	1SS	1.750	.437	545	T/U	1.625	1.812	1C	1.750	.437
1636	E	1.625	1.625	3C	1.812	.437							
1637	E	1.625	1.625	3SS	1.812	.437							
1638	E	1.625	1.625	3C	1.812	.437	282	U	1.625	1.688	3SS	1.750	.437
1639V	E	1.625	1.625	3SS	1.812	.437							
1668V	E	1.625	1.625	3TC	1.812	.437							
1670	E	1.625	1.625	3TC	1.812	.437	1103	V	SPEC*	SPEC*	25C	1.765	.375
2103	E	1.625	1.625	----	----	----							
2171A	E	1.625	1.875	1C	1.750	.437	7232	W	1.692	1.062	2	2.000	.437
2195A	E	1.625	1.625	2SS	2.000	.437	1.156 SHAFT						
2265A	E	1.625	1.625	2SS	1.750	.406	2345AN	D	2.000	.900	----	----	----
2275A	E	1.625	1.187	51	2.565	PLT							
2325AN	E	1.625	1.546	1C	1.750	.437							
2355AN	E	1.625	1.187	3SS	2.125	.437	1.181 SHAFT (30MM)						
2355AV	E	1.625	1.187	3SS	2.125	.437	31-52	C	1.875	1.062	1C	2.000	.437
2375AN	E	1.625	2.031	2B	1.812	.437	41-52	C	1.875	1.062	1C	2.250	.437
2385AN	E	1.625	1.187	2B	1.812	.437	1360A	C	1.875	1.062	1C	1.875	.437
4006A	E	1.625	1.625	1C	1.750	.437	4445A	C	1.875	1.062	1SS	2.000	.437
4945A	E	1.625	1.000	2SS	1.937	.437	5185A	C	1.875	1.062	2SS	2.000	.500
9908AN	E	1.625	1.187	1SS	1.750	.312	5280A	C	1.875	1.375	1C	----	----
9944A	E	1.625	1.187	3C	1.750	.437	9140A	C	1.875	1.375	3B	1.812	.656
9944AV	E	1.625	1.187	3C	1.750	.437	7815YB2	C	1.875	----	1C	----	----
814	J	1.590	1.000	1C	1.750	.375	136	D	2.000	1.062	1C	1.875	.437
							1179	D	2.000	1.062	1SS	1.875	.437
							1179V	D	2	1.062	1	1.875	.437
215	K	1.812	1.625	----	----	----							
861	K	1.812	1.625	----	----	----	4675A	K	1.875	2.500	3SS	1.875	.437
1176	K	1.812	1.625	1C	1.750	.437							
1177	K	1.812	1.625	1SS	1.750	.437							
2225AN	K	1.812	1.625	51	2.125	PLT	2405AN	L-1	1.812	1.250	----	----	----
2235AN	K	1.812	1.625	51	3.000	PLT							
6510AN	K	1.812	1.250	2SS	1.875	.437							
2290AN	L-1	1.787	.750	----	----	----							
5190AN	L-1	1.725	NO SPRING	----	----	----							
5295AN	L-1	1.750	1.000	----	----	----							



Part No.	Type	O.D.	OP. Height	Type	C' Bore	Thk.	Part No.	Type	O.D.	OP. Height	Type	C' Bore	Thk.
<b>1.250 SHAFT</b>							<b>1.250 SHAFT</b>						
<b>ROTARY</b>				<b>SEAT</b>			<b>ROTARY</b>				<b>SEAT</b>		
2041	D	2.000	1.062	1C	1.875	.437	394	U	1.812	1.625	3SS	1.875	.437
2042	D	2.000	1.062	1SS	1.875	.437	681	U	1.812	2.406	1C	1.875	.437
2043	D	2.000	1.062	3C	1.875	.437							
2044	D	2.000	1.062	3SS	1.875	.437	2532AV	Z	2.250	.875		SEAT UNITIZED WITH SEAL	
2550AN	D	2.000	1.062	2SS	1.937	.312	2533AV	Z	2.250	.875		SEAT UNITIZED WITH SEAL	
2595AN	D	2.000	.875	51/1SS	----	PLT	2538A	Z	2.250	.750		SEAT UNITIZED WITH SEAL	
2596AN	D	2.000	.875	52/1SS	----	PLT							
2596AV	D	2.000	.875	52/1SS	----	PLT							
3938	D	2.000	1.062	1	1.875	.437							
108N	E	1.812	1.542	1SS	1.875	.437	<b>1.312 SHAFT</b>						
137	E	1.812	1.625	1SS	1.875	.437	2503AN	C	2.062	1.000	3SS	1.875	.344
137VHD	E	1.812	1.625	3	1.875	.437	2610AN	C	2.062	1.500	----	----	----
256	E	1.812	1.187	3SS	1.875	.437	2615AN	C	2.062	1.750	2SS	2.000	.437
264	E	1.812	1.625	3SS	1.875	.437	6680AN	C	2.062	1.062	2SS	2.062	.375
264HD	E	1.812	1.625	3	1.875	.437	9500AN	C	2.062	2.000	2SS	2.062	.437
361	E	1.812	1.625	1C	1.875	.437							
361E	E	1.812	1.625	1	1.875	.437	6600AN	L-1	2.062	1.675	----	----	----
546	E	1.812	1.625	3C	1.875	.437							
1015	E	1.812	1.625	----	----	----	<b>1.375 SHAFT (35MM)</b>						
1029	E	1.812	1.625	3C	1.875	.437	60-52	C	2.062	1.125	1C	2.250	.437
1181	E	1.812	1.625	1SS	1.875	.437	172	C	2.062	1.125	----	----	----
1182	E	1.812	1.625	1C	1.875	.437	172EHD	C	2.062	1.125	----	----	----
1183	E	1.812	1.625	3SS	1.875	.437	177	C	2.062	1.125	1C	2.000	.437
1184	E	1.812	1.625	3C	1.875	.437	210	C	2.062	1.125	1SS	2.000	.437
1185N	E	1.812	1.542	1C	1.875	.437	210E	C	2.062	1.125	3	2.000	.437
1186	E	1.812	1.625	1SS	2.000	.437	467	C	2.062	1.187	2SS	2.125	.437
2128	E	1.812	2.281	3C	1.875	.437	547	C	2.062	1.125	3SS	2.000	.437
2129	E	1.812	2.281	3C	1.875	.437	805	C	2.062	1.125	3C	2.000	.437
2493AV	E	1.812	1.542	3SS	1.750	.437	919*	C	2.062	1.125	1SS	2.000	.437
2508AV	E	1.812	1.187	3SS	1.875	.437	929	C	2.062	.900	25C	2.000	.500
3913A	E	1.812	1.062	51	1.812	PLT	1062V	C	2.062	1.156	3SS	2.125	.406
4550A	E	1.812	1.625	2B	1.937	.437	1667	C	2.062	1.687	1SS	2.000	.437
5340A	E	1.812	1.187	1C	1.875	.437	1667V	C	2.062	1.687	1	2.000	.437
							2134	C	2.062	1.687	1C	2.000	.437
6265	G	1.811	1.024	1	1.875	.437	2647A	C	2.062	1.125	3SS	3.543	.437
6259	G	1.811	1.062	1	1.875	.437	2650AN	C	2.062	1.500	51	2.750	PLT
6260	G	1.811	1.062	1	1.875	.437	2680A	C	2.062	1.125	3SS	3.543	.687
6261	G	1.811	1.062	1	1.875	.437	2707A	C	2.062	1.125	3SS	3.543	.687
6264	G	1.811	1.062	1	1.875	.437	2710AN	C	2.062	1.125	----	----	----
6266	G	1.811	1.062	3	1.875	.437	2713AN	C	2.062	1.125	----	----	----
							2720AN	C	2.062	1.187	2SS	2.125	.375
815	J	1.960	1.187	1C	2.000	.375	2745A	C	2.062	1.187	1C	1.937	.375
							2756A	C	2.062	.900	----	----	----
169	K	1.937	1.625	----	----	----	4040A	C	2.062	.900	3SS	2.000	.692
169SSP	K	1.937	1.406	----	----	----	4040AV	C	2.062	.900	3SS	2.000	.692
176	K	1.937	1.406	1C/1C	1.875/2.000	.2971/297	4044	C	2.062	1.187	1	2.125	.375
228	K	1.937	1.625	3SS	1.875	.437	5676	C	2.187	.925	2	2.187	.312
883	K	1.937	1.625	1C	1.875	.437	8160A	C	2.062	1.187	2SS	2.062	.437
883V	K	1.937	1.625	1	1.875	.437	70081	C	2.062	1.125	1SS	2.832	.437
890	K	1.937	1.625	1SS	1.875	.437							
1118	K	1.937	1.625	1C	1.875	.437							
1623A	K	1.937	2.000	<sup>1</sup> C/SS	1.875	.437	7695	C/Bal.	2.062	1.437	3	1.875	.437
1623	K	1.937	2.000	3	2.125	.375	7697	C/Bal.	2.062	1.437	3	1.875	.437
2590A	K	1.937	1.875	51/2	<sup>2.125</sup> PLATE	.437	7795	C/Bal.	2.062	1.437	3	1.875	.437
3977A	K	1.937	1.625	2SS	2.250	.437							
4406A	K	1.750	2.500	3SS	1.906	.437							
4406AV	K	1.750	2.500	3SS	1.906	.437							
4675A	K	1.937	2.500	3SS	1.875	.437							
7323	K	1.937	1.750	1	1.875	.437							
2520AN	L-1	2.218	1.625	----	----	----							
2570AN	L-1	2.000	NO SPRING	1CA	2.078	.406							
2485AN	L-2	1.875	1.750	----	----	----							
7925AN	L-2	1.875	2.500	----	----	----							
426	R	2.000	1.875	1C	1.875	.437							
794	S	2.296	2.218	8S	2.125	.281							
3923AN	S	<sup>2.250</sup> BORE	2.000	8SS	2.125	.281							
308N	T	1.812	2.375	3SS	1.875	.437							
1187	T	1.812	2.375	1C	1.875	.437							
2211	T	1.812	2.375	3	1.875	.437							
2494A	T	1.812	1.625	1C	1.875	.437							
3607	T	1.812	2.375	3	1.875	.437							

Part No.	Type	O.D.	OP. Height	Type	C' Bore	Thk.	Part No.	Type	O.D.	OP. Height	Type	C' Bore	Thk.
<b>1.375 SHAFT (35MM)</b>							<b>1.375 SHAFT (35MM)</b>						
<b>ROTARY</b>				<b>SEAT</b>			<b>ROTARY</b>				<b>SEAT</b>		
186	D	2.187	1.125	1SS	2.000	.437	3854	Q	2.515	.625	25	2.000	.281
376	D	2.187	1.125	----	----	----							
376V	D	2.187	1.125	----	----	----	178	R	2.187	2.187	1C	2.000	.437
404	D	2.187	1.093	25C	2.000	.500							
491	D	2.187	1.125	1C	2.000	.437	11451-2	SP	1.875	----	2SS	2.125	----
806	D	2.187	1.125	3SS	2.000	.437							
807	D	2.187	1.125	3SS	2.000	.437	690BW	T	1.875	2.437	1C	2.000	.437
1132NW	D	2.187	1.093	1C	2.000	.437	725	T	1.875	2.437	1C	2.000	.437
2045	D	2.187	1.125	1C	2.000	.437	726	T	1.875	2.437	1SS	2.000	.437
2046	D	2.187	1.125	1SS	2.000	.437	2635AN	T	1.875	1.687	----	----	----
2047	D	2.187	1.125	3C	2.000	.437							
2048	D	2.187	1.125	3SS	2.000	.437	396BW	T/U	1.875	2.687	1C	2.000	.437
2772AV	D	2.187	.800	3SS	2.687	.380	1188BW	T/U	1.875	2.687	1C	2.000	.437
4123	D	2.000	1.256	3	2.000	.437							
6048	D	2.250	1.006	3	2.000	.218	561	U	1.875	2.125	2SS	2.000	.437
							561SS	U	1.875	2.125	2SS	2.000	.437
							1104	V	SPEC*	2.812	25C	2.140	.437
257	E	1.875	1.187	3SS	2.000	.437							
354	E	1.875	1.687	1C	2.000	.437	<b>1.406 SHAFT</b>						
677	E	1.875	1.687	1SS	2.000	.437	4685AN	C	2.062	1.187	----	----	----
808	E	1.875	1.687	3C	2.000	.437							
809	E	1.875	1.687	3SS	2.000	.437	<b>1.437 SHAFT</b>						
864	E	1.875	2.000	3C	2.000	.437	2156	C	2.125	1.125	3SS	2.250	.625
865	E	1.875	2.000	3SS	2.000	.437	2785A	C	2.125	1.000	2SS	2.187	.312
2049	E	1.875	1.687	1C	2.000	.437	2785AV	C	2.125	1.000	2SS	2.187	.312
2049V	E	1.875	1.687	1	2.000	.437	7105	C	2.125	1.250	3	2.250	.375
2050	E	1.875	1.687	1SS	2.000	.437	8310A	C	2.125	1.125	2SS	2.187	.500
2104	E	1.875	1.687	----	----	----	8310AV	C	2.125	1.125	2SS	2.187	.500
2104V	E	1.875	1.687	----	----	----							
2657A	E	1.875	1.187	3SS	2.000	.437							
2775A	E	1.875	1.687	2SS	2.000	.437							
3783	E	1.875	1.625	3	2.125	.437	4545A	D	2.312	1.000	1C	2.062	.437
3901	E	1.875	2.031	3	2.000	.437	4925A	D	2.312	1.000	3SS	3.875	.437
3925	E	1.875	1.637	3	2.125	.437	4930A	D	2.312	1.000	1C	2.250	.437
4119AN	E	1.875	2.375	52	----	PLT	4931A	D	2.312	1.250	3SS	2.250	.437
6830A	E	1.875	1.687	1C	2.000	.375							
9957A	E	1.875	1.187	3SS	2.000	.437							
9957AV	E	1.875	1.187	3SS	2.000	.437							
3769	E/Bal.	1.875	2.000	3	1.875	.437	334	E	1.937	1.625	2SS	2.062	.437
3991	E/Bal.	1.875	2.000	3	1.875	.437	705	E	1.937	1.688	3C	2.062	.437
7702	E/Bal.	1.875	2.000	3	1.875	.437	943N	E	1.937	1.516	3SS	2.312	.360
							943V	E	2.110	1.516	3	2.312	.360
291	J	2.125	1.187	1C	2.125	.375	1634	E	1.937	1.250	3SS	2.250	.375
							1635	E	1.937	1.250	3SS	2.250	.375
209	K	2.062	1.625	----	----	----	2234	E	1.937	1.688	3	2.062	.437
495	K	2.062	1.625	1C	2.000	.437	2234V	E	1.937	1.688	3	2.062	.437
540	K	2.062	1.625	1SS	2.000	.437	2790AN	E	1.937	1.516	51	2.750	PLT
2640AN	K	2.062	1.375	3SS	----	PLT	2810AN	E	1.937	1.250	----	----	----
2645A	K	2.062	2.000	51	----	PLT	2811AN	E	1.937	1.516	52	----	PLT
2665A	K	2.062	2.250	----	----	----	3848	E	2.109	1.515	3	2.310	.359
2695A	K	2.062	1.625	1C/3SS	2.000/2.125	.375	4067	E	1.937	1.688	3	2.125	.437
2730AN	K	2.062	2.000	----	----	----	6055	E	1.937	1.688	28	2.125	.437
2760AN	K	2.062	1.950	----	----	----	6075AN	E	1.937	1.250	2SS	2.250	.312
3935A	K	2.062	2.500	1C	2.000	.437	7930AN	E	1.937	1.516	51	----	PLT
4851A	K	2.062	2.000	3SS	2.250	.500							
2760AN	L-1	2.000	1.750	----	----	----							
2725AN	L-1	2.062	.900	----	----	----							
8155AN	L-1	2.000	1.675	----	----	----							
2670AN	L-2	2.000	2.500	2B	2.406	.437							
2675AN	L-2	1.875	1.125	2B	2.031	.406							
4793A	L-2	1.938	2.250	25CA	2.143	.733							

Part No.	Type	O.D.	OP. Height	Type	C' Bore	Thk.	Part No.	Type	O.D.	OP. Height	Type	C' Bore	Thk.	
<b>1.437 SHAFT</b>							<b>1.500 SHAFT (38MM)</b>							
<b>ROTARY</b>				<b>SEAT</b>			<b>ROTARY</b>				<b>SEAT</b>			
862		2.125	1.750	----	----	----	283	D	2.312	1.125	1C	2.156	.437	
2284AN	K	2.125	2.125	3SS	2.188	.375	371	D	2.312	1.125	1SS	1.125	.437	
2284AV	K	2.125	2.125	3SS	2.188	.375	382	D	2.312	1.125	1C	1.125	.437	
6890A	K	2.125	1.750	2SS	2.375	.437	534	D	2.312	1.125	3SS	1.125	.437	
8620AN	K	2.125	1.750	----	----	----	599N	D	2.312	1.000	3SS	2.187	.437	
							817	D	2.312	1.125	3C	2.125	.437	
							939	D	2.312	1.125	----	----	----	
2780AN	L-2	2.062	2.250	----	----	----	1028ASC	D	2.312	1.125	1SC	2.375	SP	
							2051	D	2.312	1.125	1C	2.125	.437	
							2052	D	2.312	1.125	1SS	2.125	.437	
1633N	T	1.937	2.125	3SS	2.187	.375	2053	D	2.312	1.125	3C	2.125	.437	
							2054	D	2.312	1.125	3SS	2.125	.437	
							2127V	D	2.312	1.125	3SS	2.125	.437	
<b>1.475 SHAFT</b>							2940A	D	2.312	1.125	----	----	----	
5205AN	D	2.312	2.375	----	----	----	7079	D	2.375	1.125	28	2.375	.618	
<b>1.490 SHAFT</b>														
2820AN	C	2.187	3.000	2B	2.250	.437								
<b>1.500 SHAFT (38MM)</b>														
192N	C	2.187	1.437	3SS	2.125	.437								
247*	C	2.187	1.125	1SS	2.156	.437								
320	C	2.187	1.125	1C	2.250	.437								
347*	C	2.187	1.125	1C	2.125	.437								
378*	C	2.187	1.125	1SS	2.125	.437								
553	C	2.187	1.125	3SS	2.125	.437								
659	C	2.187	1.125	1SS	2.125	.437	224N	E	2.000	1.688	3SS	2.125	.437	
659TC	C	2.187	1.125	1	2.125	.437	258	E	2.000	1.688	3SS	2.125	.437	
659VCHD	C	2.187	1.125	1	2.125	.437	259	E	2.000	1.187	3SS	2.125	.437	
659VTCVSTC	C	2.187	1.125	1	2.125	.437	305	E	2.000	1.688	1C	2.125	.437	
682*	C	2.187	1.125	1C	2.156	.437	305E	E	2.000	1.688	1	2.125	.437	
758	C	2.187	1.125	1C	2.125	.437	314	E	2.000	1.688	3C	2.000	.437	
758E	C	2.187	1.125	1	2.125	.437	316	E	2.000	1.688	3SS	2.000	.437	
758SC	C	2.187	1.125	1	2.125	.437	374	E	2.000	1.688	1SS	2.125	.437	
758SCSC	C	2.187	1.125	1	2.125	.437	395	E	2.000	1.688	3C	2.125	.437	
758VSCSC	C	2.187	1.125	1	2.125	.437	395E	E	2.000	1.688	3	2.125	.437	
758VSC	C	2.187	1.125	1	2.125	.437	515	E	2.000	1.688	3C	2.250	.437	
816	C	2.187	1.125	3C	2.125	.437	620	E	2.000	2.062	3C	2.312	.437	
926	C	2.187	1.125	3C	2.312	.437	629	E	2.000	2.062	3SS	2.312	.437	
1017AN	C	2.187	1.687	52	3.062	PLT	899	E	2.000	1.562	3C	2.125	.437	
1019AN	C	2.187	1.125	51	3.500	PLT	947	E	2.000	2.062	3C	2.312	.437	
1110	C	2.187	1.687	3SS	2.125	.437	950	E	2.000	2.062	3SS	2.312	.437	
1110V	C	2.187	1.687	3	2.125	.437	1190	E	2.000	1.688	1C	2.125	.437	
1144V	C	2.187	1.125	3SS	2.125	.437	1191	E	2.000	1.688	1SS	2.125	.437	
1189	C	2.187	1.125	1C	2.250	.437	1192	E	2.000	1.688	3SS	2.125	.437	
1921AN	C	2.187	1.687	51	2.875	PLT	1640	E	2.000	1.688	3TC	2.125	.437	
19211AN	C	2.187	1.687	----	----	----	1641	E	2.000	1.688	3C	2.125	.437	
2105	C	2.187	1.125	----	----	----	1642	E	2.000	1.688	3SS	2.125	.437	
2120AN	C	2.187	1.687	2B	2.250	.562	1643	E	2.000	1.688	3TC	2.125	.437	
2209	C	2.187	1.125	1	2.125	.437	1644V	E	2.000	1.688	3C	2.125	.437	
2217	C	2.187	1.125	3	2.125	.437	1645V	E	2.000	1.688	3SS	2.125	.437	
2221	C	2.187	1.687	3	2.125	.437	1646	E	2.000	1.688	3TC	2.125	.437	
2223	C	2.187	1.125	3	2.125	.437	1647B/V	E	2.000	1.688	3C	2.312	.437	
2232	C	2.187	1.125	1	2.125	.437	1648B/V	E	2.000	1.688	3SS	2.312	.437	
2845A	C	2.187	1.125	2SS	2.125	.406	1649	E	2.000	1.688	3C	2.312	.437	
2870AN	C	2.187	1.687	51	3.500	PLT	1650	E	2.000	1.688	3SS	2.312	.437	
2890AN	C	2.187	1.687	51	2.562	PLT	1651V	E	2.000	1.688	3C	2.312	.437	
2895A	C	2.187	1.000	1C	2.156	.437	1652V	E	2.000	1.688	3SS	2.312	.437	
2909A	C	2.187	.875	3SS	2.125	.312	1671	E	2.000	1.688	3TC	2.312	.437	
2910AN	C	2.187	1.125	2B	2.250	.375	1673	E	2.000	1.688	3TC	2.312	.437	
2920AN	C	2.187	1.687	----	----	----	1690V	E	2.000	2.062	3C	2.312	.437	
2925AN	C	2.187	2.125	----	----	----	1691V	E	2.000	2.062	3SS	2.312	.437	
2935AN	C	2.187	1.125	----	----	----	1692V	E	2.000	2.062	3TC	2.312	.437	
3821A	C	2.187	1.125	1SS	2.125	.437	2106	E	2.000	1.688	----	----	.437	
3979	C	2.187	1.125	Spec.	2.740	.875	2106HD	E	2.000	1.688	----	----	----	
5670AN	C	2.187	1.687	52	----	PLT	2117	E	2.000	1.688	1C	2.250	.473	
6170AN	C	2.187	2.000	51	3.610	PLT	2137	E	2.000	1.688	1SS	2.156	.437	
6222	C	2.187	1.125	1	2.125	.437	2837ASC	E	2.000	1.187	3SC	2.125	.375	
7409	C	2.187	1.125	1	2.125	.437	7562	E	2.000	1.688	3	2.125	.437	
7632	C	2.187	1.125	1	2.125	.437	7933	E	2.000	1.688	1	2.125	.437	
7792	C	2.187	1.125	1	2.125	.437								
7953	C	2.187	1.125	1	2.125	.437								
9918AN	C	2.187	2.000	----	----	----	4088	E/Bal.	2.000	2.000	3	2.000	.437	
14122AN	C	2.187	1.687	52	----	PLT								
2851AMP	SC	2.062	.700	3SC	2.125	.312	292	J	2.210	1.250	1C	2.250	.375	

Part No.	Type	O.D.	OP. Height	Type	C' Bore	Thk.	Part No.	Type	O.D.	OP. Height	Type	C' Bore	Thk.	
<b>1.500 SHAFT (38MM)</b>							<b>1.562 SHAFT</b>							
<b>ROTARY</b>				<b>SEAT</b>			<b>ROTARY</b>				<b>SEAT</b>			
216	K	2.187	1.625	----	----	----	1949AV	Z	2.625	.950	SEAT UNITIZED WITH SEAL			
541	K	2.187	1.625	1C	2.125	.437	2967AV	Z	2.625	.950	SEAT UNITIZED WITH SEAL			
884	K	2.187	1.625	1SS	2.125	.437								
1624	K	2.187	2.125	3C/3S	2.312	.437								
2850AN	K	2.187	2.000	----	----	----	<b>1.575 SHAFT (40MM)</b>							
2860AN	K	2.187	1.687	51	2.250	PLT	4960A	C	2.187	2.000	1C	2.375	.468	
2945A	K	2.187	1.687	2SS	2.250	.312								
2955A	K	2.187	2.000	3B/5 1	PLT 2.312	.562								
3918A	K	2.187	1.687	3TCIC	2.187/2.125	.812/.438	4955A	D	2.312	2.000	2SS	2.500	.406	
3919A	K	2.187	1.687	3SS	2.125/2.000	.447/.880	4956A	D	2.312	2.000	2SS	2.500	.312	
							4957A	D	2.312	2.000	2SS	2.500	.406	
2875AN	L-1	2.000	1.437	----	----	----								
							<b>1.594 SHAFT</b>							
2930AN	L-2	2.125	1.875	----	----	----	2980A	C	2.500	1.687	2SS	2.375	.437	
4791A	L-2	2.062	1.437	3CA	2.500	.828								
							<b>1.601 SHAFT</b>							
9930A	M	2.252	.350	8SS	M.O.S.	.152	4852AN	K	2.500	2.000	3SS	2.500	.500	
431	R	2.312	1.875	1C	2.125	.437	<b>1.625 SHAFT</b>							
432	R	2.312	1.875	1SS	2.125	.437	238	C	2.500	1.375	1C	2.375	.500	
							238E	C	2.500	1.375	1	2.375	.500	
							238VSC	C	2.500	1.375	1	2.375	.500	
1500G	S	----	----	8SS	SP	----	239	C	2.500	1.375	1SS	2.375	.500	
							239E	C	2.500	1.375	3	2.375	.500	
691	T	2.000	2.437	1C	2.125	.437	239E	C	2.500	1.375	3	2.375	.500	
868	T	2.000	2.437	1C	2.125	.437	544	C	2.500	1.375	3SS	2.375	.500	
							818	C	2.500	1.375	3C	2.375	.500	
915	U	2.000	2.062	3C	2.000	.437	1019	C	2.500	1.375	3SS	2.625	.500	
							1035	C	2.500	1.375	28SS	3.544	1.250	
1943AV	Z	2.500	.850	SEAT UNITIZED WITH SEAL				1039	C	2.500	1.375	28SS	3.544	1.250
							2107	C	2.500	1.375	----	----	----	
							2201	C	2.500	1.375	3	2.625	.500	
							2202	C	2.500	1.375	3	2.625	.500	
							3015AN	C	2.500	1.375	51	3.000	PLT	
							3020A	C	2.500	1.375	3SS	2.437	.375	
							3020AV	C	2.500	1.375	3SS	2.437	.375	
							3022A	C	2.500	1.125	52	----	PLT	
							3025AN	C	2.500	1.375	2B	2.500	.500	
							3035A	C	2.500	1.375	2SS	2.375	.500	
							3055A	C	2.500	1.000	2SS	2.469	.250	
							3055AV	C	2.500	1.000	2SS	2.469	.250	
							3066AE	C	2.500	1.000	2SS	2.469	.250	
							3075A	C	2.500	1.125	8SS	----	PLT	
							3664	C	2.500	1.375	1	2.375	.500	
							6685AN	C	2.500	1.375	2SS	2.375	.375	
							6995A	C	2.000	1.375	2SS	2.312	.500	
							7017	C	2.500	1.375	3	2.375	.500	
							7497	C	2.500	1.312	25	2.500	.812	
							7885AV	C	2.500	.800	3SS	2.750	.312	
							331	D	2.718	1.125	3SS	2.437	.500	
							461	D	2.718	1.375	1SS	2.375	.500	
							514	D	2.718	1.375	1C	2.375	.500	
							514VHD	D	2.718	1.375	1	2.375	.500	
							514DS	D	2.718	----	1C	2.375	----	
							819	D	2.718	1.375	3SS	2.375	.500	
							821	D	2.718	1.375	3C	2.375	.500	
							1697	D	2.718	1.375	3SS	2.375	.500	
							1698	D	2.718	1.375	3C	2.375	.500	
							2055	D	2.718	1.375	1C	2.375	.500	
							2056	D	2.718	1.375	1SS	2.375	.500	
							2165	D	2.718	1.375	28SS	3.544	1.250	
							6262	G	2.205	1.375	1	2.375	.500	
							6263	G	2.205	1.375	1	2.375	.500	
							1195	K	2.500	2.125	1	2.375	.500	

Part No.	Type	O.D.	OP. Height	Type	C' Bore	Thk.	Part No.	Type	O.D.	OP. Height	Type	C' Bore	Thk.
<b>1.625 SHAFT</b>							<b>1.750 SHAFT</b>						
<b>ROTARY</b>			<b>SEAT</b>				<b>ROTARY</b>			<b>SEAT</b>			
346	E	2.250	2.000	1C	2.312	.500	387	C	2.625	1.375	3C	2.625	.500
484	E	2.250	2.000	1SS	2.312	.500	434	C	2.625	1.375	1C	2.500	.500
595	E	2.250	2.000	3C	2.375	.500	436	C	2.625	1.375	3SS	2.500	.500
609	E	2.250	2.000	1C	2.312	.500	436E	C	2.625	1.375	3	2.500	.500
610	E	2.250	2.000	1SS	2.312	.500	436SCSC	C	2.625	1.375	3	2.500	.500
744	E	2.250	2.000	1SS	2.375	.500	436TCTC	C	2.625	1.375	3	2.500	.500
745	E	2.250	2.000	1SS	2.375	.500	446	C	2.625	1.375	1C	2.500	.500
747	E	2.250	2.000	1C	2.375	.500	446HD	C	2.625	1.375	1	2.500	.500
822	E	2.250	2.000	3SS	2.375	.500	446TCTC	C	2.625	1.375	1	2.500	.500
1683	E	2.250	2.000	3C	2.375	.500	446VHD	C	2.625	1.375	3	2.500	.500
1699	E	2.250	2.000	3SS	2.375	.500	448	C	2.625	1.375	1SS	2.500	.500
2057	E	2.250	2.000	1C	2.375	.500	448HD	C	2.625	1.375	1	2.500	.500
2058	E	2.250	2.000	1SS	2.375	.500	448VSCSC	C	2.625	1.375	1	2.500	.500
4280A	E	2.250	2.000	1C	2.750	.468	550	C	2.625	1.375	3C	2.500	.500
4300A	E	2.250	2.000	1C	2.375	.468	1038	C	2.625	1.375	28	3.544	.500
5225A	E	2.250	1.375	1SS	2.375	.531	1055	C	2.625	1.125	----	----	----
8005A	E	2.312	2.000	2SS	2.312	.500	1056	C	2.625	1.125	3SS	2.500	.437
8115A	E	2.250	1.375	1C	2.375	.468	1068	C	2.625	1.125	1SS	2.500	.500
							1674	C	2.625	2.000	1SS	2.500	.500
							1674CE	C	2.625	2.000	1C	2.500	.500
195	K	2.500	2.125	1SS	2.375	.500	1674CEV	C	2.625	2.000	1C	2.500	.500
3978AN	K	2.500	2.375	2SS	2.625	.437	2108	C	2.625	1.375	----	----	----
							2108V	C	2.625	1.375	----	----	----
							2130A	C	2.625	1.375	52/2S	2.500	PLT
3005A	L-2	2.250	2.375	----	----	----	2135	C	2.625	2.000	1C	2.500	.500
							2142	C	2.625	2.000	1SS	2.500	.500
							2150	C	2.625	2.000	3C	2.500	.500
281	R	2.718	2.125	3SS	2.375	.500	2151	C	2.625	2.000	3SS	2.500	.500
							2151V	C	2.625	2.000	3	2.500	.500
							2207	C	2.625	1.375	3	2.500	.500
692	T	2.250	2.875	1C	2.375	.500	2210	C	2.625	1.375	1	2.500	.500
							2212	C	2.625	1.125	1	2.500	.500
							2212TCTC	C	2.625	1.125	1	2.500	.500
458	U	2.250	2.875	1C	2.375	.500	3105A	C	2.625	1.125	1B	2.625	.468
							3120AN	C	2.625	1.375	3SS	3.344	.562
							3135AN	C	2.625	1.375	51	2.812	PLT
							3145AV	C	2.625	1.375	2SS	2.500	.500
							3170A	C	2.625	.900	2SS	2.656	.375
							3190AN	C	2.625	1.850	51	2.750	PLT
							3271A	C	2.625	2.000	2SS	2.500	.484
							3687	C	2.625	1.062	3	2.500	.500
							3718V	C	2.625	1.062	3	2.500	.500
							3719	C	2.625	1.125	3	2.500	.500
							3963	C	2.625	1.062	3	2.500	.500
							6210	C	2.625	1.375	1	2.500	.500
							6211	C	2.625	1.375	1	2.500	.500
							6241	C	2.625	1.062	3	2.500	.500
6612A	E	2.375	1.500	2B	2.594	.375	6690AN	C	2.625	1.375	2SS	2.625	.688
							7035	C	2.625	1.375	3	2.500	.500
							7886AV	C	2.625	.800	3SS	2.500	.312
3090AN	K	2.375	1.500	3B	2.312	.500	7975AN	C	2.625	1.375	2SS	2.500	.468
							9947A	C	2.625	1.125	3SS	2.500	.500
8010AN	L-1	2.500	1.125	----	----	----							
							147	D	2.750	1.375	----	----	----
							237	D	2.750	1.375	1C	2.500	.500
							288	D	2.750	1.375	1SS	2.500	.500
							568N	D	2.750	1.781	3SS	2.456	.468
							825	D	2.750	1.375	3SS	2.500	.500
							826	D	2.750	1.375	3C	2.500	.500
							1004AN	D	2.750	.900	52/2S	PLT/2.656	PLT
							1059AN	D	2.750	.900	2SS	2.656	.375
							2059	D	2.750	1.375	1C	2.500	.500
							2060	D	2.750	1.375	1SS	2.500	.500
							2061	D	2.750	1.375	3C	2.500	.500
							2062	D	2.750	1.375	3SS	2.500	.500
							3113AN	D	2.750	1.100	3SS	2.500	.500
							3115AN	D	2.750	1.375	----	----	----
							3136A	D	2.750	1.375	3B	2.500	.500
							6217	D	2.750	1.375	1	2.500	.500



Part No.	Type	O.D.	OP. Height	Type	C' Bore	Thk.	Part No.	Type	O.D.	OP. Height	Type	C' Bore	Thk.
<b>1.750 SHAFT</b>							<b>1750 SHAFT</b>						
<b>ROTARY SEAT</b>							<b>ROTARY SEAT</b>						
205	E	2.375	2.000	1C	2.500	.500	674	T	2.375	2.875	1C	2.500	.500
205TCTC	E	2.375	2.000	1	2.500	.500	675	T	2.375	2.875	1SS	2.500	.500
262	E	2.375	2.000	3SS	2.500	.500	2144	T	2.375	2.750	3C	2.500	.500
262E	E	2.375	2.000	3	2.500	.500	1067AN	T	2.375	2.875	3SS	2.500	.500
317	E	2.375	2.000	1C	2.487	.500	3095AN	T	2.375	1.750	2SS	2.573	.437
366	E	2.375	2.000	1S	2.500	.500	3111A	T	2.375	1.750	1C	2.500	.500
366HD	E	2.375	2.000	1	2.500	.500	3208A	T	2.375	2.250	3SS	2.500	.500
366VCHD	E	2.375	2.000	1	2.500	.500	3255AN	T	2.375	2.875	----	----	----
535	E	2.375	2.000	3C	2.500	.500	3260AN	T	2.375	3.750	----	----	----
858	E	2.375	2.000	3C	2.500	.500	4249A	T	2.375	2.250	1C	2.500	.500
859	E	2.375	2.000	3SS	2.500	.500	6242	T	2.375	2.281	3	2.500	.500
859TC	E	2.375	2.000	3	2.500	.500							
1031V	E	2.375	2.000	3SS	2.500	.500							
1032	E	2.375	2.000	1SS	2.500	.500	455	T/U	2.375	3.125	1C	2.500	.500
1033	E	2.375	2.000	1SS	2.500	.500	1198	T/U	2.375	3.125	1C	2.500	.500
1078	E	2.375	2.000	27C	3.000	1.000							
1196	E	2.375	2.000	1C	2.500	.500							
1684	E	2.375	2.000	3C	2.312	.500	519	U	2.375	2.500	3C	2.500	.500
2109	E	2.375	2.000	----	----	----	555	U	2.375	2.500	2SS	2.500	.500
2130	E	2.375	2.000	3C	2.625	.500	555SS	U	2.375	2.500	2SS	2.500	.500
3106A	E	2.375	1.500	1C	2.500	.500	917	U	2.375	2.437	3C	2.500	.500
3106AV	E	2.375	1.500	1C	2.500	.500	1042	U	2.375	2.500	1C	2.500	.500
3666A	E	2.375	1.500	2SS	2.500	.469	1070	U	2.375	2.500	3C	2.375	.500
4735AV	E	2.375	1.150	2SS	2.500	.406	1199	U	2.375	2.500	3SS	2.500	.500
5325AV	E	2.375	2.000	1C	2.625	.496	2157	U	2.375	2.000	3SS	2.500	.500
6090	E	2.375	1.437	3	2.500	.500	2170	U	2.375	2.000	3C	2.500	.500
6235	E	2.375	2.000	1	2.500	.500	4390A	U	2.375	2.000	1C	2.500	.500
7252	E	2.375	1.312	1	2.625	.500	5681A	U	2.375	2.000	2SS	2.500	.468
7924	E	2.375	2.000	3	2.500	.500	5681AV	U	2.375	2.000	2SS	2.500	.468
7950	E	2.375	1.937	3	2.500	.500	5682A	U	2.375	2.000	2SS	2.375	.468
8016AV	E	2.375	1.050	1C	2.500	.492	5685A	U	2.375	2.000	2SS	2.500	.468
9911AV	E	2.375	1.500	1SS	2.500	.500	7090	U	2.375	2.000	3	2.500	.500
9945A	E	2.375	2.000	27SS	2.990	1.000							
9960A	E	2.375	1.500	3C	2.500	.500							
9961A	E	2.375	1.500	3SS	2.500	.500	26166AV	Z	SP	2.250	1C	2.500	.500
9961AV	E	2.375	1.500	3SS	2.500	.500							
70091VLS	E	2.375	2.250	----	----	----							
2231	E/Bal.	2.375	2.375	3	2.375	.500							
2231C	E/Bal.	2.375	2.375	1	2.375	.500							
7774	E/Bal.	2.375	2.375	3	2.375	.500	<b>1.760 SHAFT</b>						
7821	E/Bal.	2.375	2.375	3	2.375	.500	3285A	E	2.375	1.500	----	----	----
7901	E/Bal.	2.375	2.375	1	2.375	.500							
							<b>1.771 SHAFT (45MM)</b>						
449	K	2.625	2.125	1C	2.500	.500	45BDC	E	2.375	2.000	1C	2.500	.500
1142	K	2.625	2.125	3C/3S	2.500	.500	719	E	2.500	2.125	1SS	2.625	.500
1197	K	2.625	2.125	1SS	2.500	.500	722	E	2.500	2.125	1C	2.625	.500
3110AN	K	2.625	2.500	----	----	----							
3125AN	K	2.625	2.125	----	----	----							
3165A	K	2.625	1.500	----	----	----	727	T	2.500	3.000	1C	2.625	.500
3205A	K	2.625	1.500	1C	2.500	.500	728	T	2.500	3.000	1SS	2.625	.500
3223A	K	2.625	1.500	2SS	2.687	.421	1057A	T	2.375	2.875	3SS	2.625	.500
4775A	K	2.625	3.000	2SS	2.500	.562							
5065A	K	2.625	2.000	2B	2.750	.500							
6246	K	2.609	1.625	1	2.500	.500	<b>1.812 SHAFT (46MM)</b>						
							3291A	D	2.875	.950	3SS	2.750	.500
3225AN	L-1	2.375	1.375	----	----	----							
3250AN	L-1	2.375	1.375	----	----	----	3245A	E	2.500	1.375	3SS	2.437	.500
							3290A	E	2.500	1.200	2SS	2.812	.375
3210AN	L-2	2.375	2.250	----	----	----	3295A	E	2.500	1.750	2B	2.750	.562
4788A	L-2	2.375	1.675	25CA	2.500	.750	3300AN	E	2.500	2.000	----	----	----
213	R	2.750	2.125	----	----	----							
217	R	2.750	2.125	1SS	2.500	.500							

Part No.	Type	O.D.	OP. Height	Type	C' Bore	Thk.	Part No.	Type	O.D.	OP. Height	Type	C' Bore	Thk.
<b>1.812 SHAFT (46MM)</b>							<b>1.875 SHAFT</b>						
<b>ROTARY</b>				<b>SEAT</b>			<b>ROTARY</b>				<b>SEAT</b>		
3297AV	Z	2.875	.900	SEAT UNITIZED WITH SEAL			1669V	E	2.500	2.125	3TC	2.687	.500
3298AV	Z	2.875	.900	SEAT UNITIZED WITH SEAL			1672V	E	2.500	2.125	3TC	2.687	.500
							1845VX	E	2.500	2.125	3C	2.687	.500
							2069	E	2.500	2.125	1C	2.625	.500
<b>1.844 SHAFT</b>							2070	E	2.500	2.125	1SS	2.625	.500
3305AN	C	2.750	2.250	2SS	2.750	.500	2071	E	2.500	2.125	3C	2.625	.500
							2072	E	2.500	2.125	3SS	2.625	.500
							2110	E	2.500	2.125	----	----	----
<b>1.875 SHAFT</b>							3315A	E	2.500	1.750	1C	2.625	.579
312	C	2.750	1.500	3SS	2.625	.500	3322AN	E	2.500	1.625	----	----	----
340	C	2.750	1.500	1C	2.625	.500	4025A	E	2.500	2.125	1SS	2.625	.453
340EC	C	2.750	1.500	1	2.625	.500	4105A	E	2.500	1.500	1C	2.625	.578
340TCSC	C	2.625	1.500	1	2.625	.500	4595AN	E	2.500	1.625	2SS	2.625	.437
340TCTC	C	2.625	1.500	1	2.625	.500	6865A	E	2.500	1.500	2SS	2.625	.469
1608	C	2.750	1.500	1SS	2.625	.500	7020	E	2.500	2.125	3	2.687	.500
2114	C	2.750	1.500	3C	2.625	.500	7869	E	2.500	2.125	1	2.625	.500
3269BLS	C	2.750	----	1	2.500	----	7962	E	2.500	2.125	3	2.625	.500
3310A	C	2.750	1.500	----	----	----	8020A	E	2.500	1.500	2SS	2.625	.469
3335AN	C	2.750	2.125	2B	2.750	.562	50089	E/SP	2.500	2.125	3TC	2.625	.500
3352AV	C	2.750	.800	3SS	2.453	.312							
3353A	C	2.750	.800	3SS	2.453	.312	3648	E/Bal.	2.500	2.500	Spec.	2.687	.500
3356A	C	2.750	1.000	8SS	3.528	.437	7827	E/Bal.	2.500	2.500	3	2.500	.500
3360AN	C	2.750	1.500	----	----	----	7884	E/Bal.	2.500	2.500	3	2.500	.500
3365A	C	2.750	.950	----	----	----	7884V	E/Bal.	2.500	2.500	3	2.500	.500
3370AN	C	2.750	1.625	51	----	PLT							
4645A	C	2.750	1.000	2B	3.000	.437							
4485A	C	2.750	1.750	1C	2.625	.578	318	K	2.750	2.125	1C	2.625	.500
7935AN	C	2.750	1.750	51	----	PLT	1693	K	2.750	2.125	1SS	2.625	.500
							2237	K	2.750	1.750	1	2.625	.500
							3694	K	2.500	2.500	3	2.625	.437
223	D	2.875	1.500	----	----	----	7352	K	2.750	2.125	1	2.625	.500
593	D	2.875	1.500	3SS	2.625	.500							
828	D	2.875	1.500	1C	2.625	.500	4787A	L-1	2.562	1.150	25CA	2.625	.500
1097	D	2.875	1.500	1SS	2.625	.500							
1620	D	2.875	1.500	3C	2.625	.500	4790A	L-2	2.562	1.750	25CA	2.625	.500
2065	D	2.875	1.500	1C	2.625	.500	4790AV	L-2	2.562	1.750	25CA	2.625	.500
2066	D	2.875	1.500	1SS	2.625	.500	7940AN	L-2	2.500	2.625	51	2.871	PLT
2067	D	2.875	1.500	3C	2.625	.500							
2068	D	2.875	1.500	3SS	2.625	.500							
46512	D	2.875	----	SP	SP	----	742	T	2.500	3.000	1C	2.625	.500
							743	T	2.500	3.000	1SS	2.625	.500
513	E	2.500	2.125	1SS	2.625	.500	1653V	T	2.500	3.000	3C	2.687	.500
523	E	2.500	2.125	1C	2.625	.500	2087A	T	2.500	3.000	1C	2.625	.578
586	E	2.500	2.125	3SS	2.625	.500	3320AN	T	2.500	1.187	----	----	----
586TCTC	E	2.500	2.125	3TC	2.625	.500	3321AN	T	2.500	1.187	8SS	2.625	.312
829	E	2.500	2.437	3C	2.687	.500	3979A	T	2.500	1.187	2SS	2.875	.437
831	E	2.500	2.437	3SS	2.687	.500	4487A	T	2.500	1.187	1C	2.625	.578
946	E	2.500	2.437	3C	2.687	.500	4780AN	T	2.500	2.250	1SS	2.625	.453
949	E	2.500	2.437	3SS	2.687	.500	4805AN	T	2.500	3.000	2SS	2.625	.469
1654	E	2.500	2.125	3C	2.625	.500							
1655	E	2.500	2.125	3TC	2.625	.500							
1656	E	2.500	2.125	3C	2.625	.500	538	U	2.500	2.437	1C	2.625	.500
1657	E	2.500	2.125	3SS	2.625	.500	538S	U	2.500	----	2SS	2.625	----
1658	E	2.500	2.125	3TC	2.625	.500	554	U	2.500	2.437	3SS	2.500	.500
1659V	E	2.500	2.062	3C	2.625	.500	898	U	2.500	2.437	3C	2.500	.500
1660V	E	2.500	2.062	3SS	2.625	.500							
1661V	E	2.500	2.062	3TC	2.625	.500							
1662V	E	2.500	2.125	3	2.687	.500	1105	V	2.500	2.000	25C	2.640	.406
1662B/V	E	2.500	2.125	3C	2.687	.500	1108	V	2.500	2.000	1C	2.625	.500
1663B/V	E	2.500	2.125	3SS	2.687	.500	21456	V	2.500	2.000	3C	2.625	.437
1664B/V	E	2.500	2.125	3C	2.687	.500							
1665B/V	E	2.500	2.125	3SS	2.687	.500							

Part No.	Type	O.D.	OP. Height	Type	C' Bore	Thk.	Part No.	Type	O.D.	OP. Height	Type	C' Bore	Thk.
<b>1.937 SHAFT</b>							<b>2.000 SHAFT</b>						
<b>ROTARY</b>			<b>SEAT</b>				<b>ROTARY</b>			<b>SEAT</b>			
3380AV	C	2.750	1.500	2SS	3.000	.375	193	D	3.000	1.500	3SS	2.750	.500
3970A	C	2.750	1.250	3SS	2.750	.500	196	D	3.000	1.500	----	----	----
							333N	D	3.000	1.500	3SS	2.812	.500
							445	D	3.000	1.500	1C	2.750	.500
3385AN	L-1	2.562	1.875	----	----	----	462	D	3.000	1.500	1SS	2.750	.500
							832	D	3.000	1.500	3SS	2.750	.500
							833	D	3.000	1.500	3C	2.750	.500
3375AN	L-2	2.562	1.250	----	----	----	876	D	3.000	1.500	1SS	2.625	.500
3390AN	L-2	2.562	3.750	----	----	----	1134	D	3.000	1.500	3SS	2.750	.500
							2073	D	3.000	1.500	1C	2.750	.500
							2074	D	3.000	1.500	1SS	2.750	.500
							2075	D	3.000	1.500	3C	2.750	.500
							2076	D	3.000	1.500	3SS	2.750	.500
<b>2.000 SHAFT</b>													
267	C	2.875	1.500	1C	2.750	.500	319	E	2.625	2.125	1C	2.687	.500
267SCSC	C	2.875	1.500	1	2.750	.500	342N	E	2.625	2.125	3SS	2.750	.500
267VTC	C	2.875	1.500	3	2.750	.500	477	E	2.625	2.125	3SS	2.750	.500
267VSCSC	C	2.875	1.500	3	2.750	.500	477E	E	2.625	2.125	3	2.750	.500
332	C	2.875	1.500	3SS	2.750	.500	478	E	2.625	2.125	1SS	2.687	.500
435	C	2.875	1.218	17CS	2.750	.812	479	E	2.625	2.125	1C	2.750	.500
532	C	2.875	1.500	3C	2.750	.500	530	E	2.625	2.125	3C	2.750	.500
576	C	2.875	1.231	2SS	3.060	.250	843	E	2.625	2.125	1SS	2.750	.500
582	C	2.875	1.125	3SS	3.000	.500	1018A	E	2.625	1.500	3SS	2.750	.500
842	C	2.875	1.500	1SS	2.750	.500	1033A	E	2.625	1.500	51	4.000	PLT
842HD	C	2.875	1.500	1	2.750	.500	1033AV	E	2.625	1.500	51	4.000	PLT
1017	C	2.875	2.125	1SS	2.750	.500	1609	E	2.625	2.125	1SS	2.625	.500
1020	C	2.875	1.500	3SS	3.000	.500	1685	E	2.625	2.125	3C	2.625	.500
1022AN	C	2.875	1.750	51	----	PLT	2077	E	2.625	2.125	1C	2.750	.500
1024AN	C	2.875	1.750	52	2.937	.437	2078	E	2.625	2.125	1SS	2.750	.500
1028	C	2.875	1.250	1SS	2.750	.500	2079	E	2.625	2.125	3SS	2.750	.500
1029AN	C	2.875	3.000	51	3.750	PLT	2112	E	2.625	2.125	----	----	----
1037	C	2.875	1.500	28	4.330	1.060	2112V	E	2.625	2.125	----	----	----
1037V^	C	2.875	1.500	28	4.330	1.060	3999	E	2.625	2.125	3	2.750	.500
1145V	C	2.875	1.500	3SS	2.750	.500	5265A	E	2.625	2.500	1SS	2.750	.440
2111	C	2.875	1.500	----	----	----							
2133	C	2.875	2.125	1C	2.750	.500	7890	E/Bal.	2.625	2.500	1	2.625	.500
2139	C	2.875	1.250	1C	2.750	.500	7892	E/Bal.	2.625	2.500	3	2.625	.500
2219	C	2.875	1.500	1	2.750	.500	7910	E/Bal.	2.625	2.500	3	2.625	.500
3415AN	C	2.875	1.500	51	4.005	PLT							
3420AN	C	2.875	1.500	----	----	----							
3425AN	C	2.875	2.500	2SS	2.875	.500							
3426AN	C	2.875	1.125	2SS	2.937	.500							
3445AN	C	2.875	3.000	51	3.750	PLT							
3460AN	C	2.875	1.750	51	----	PLT							
3470A	C	2.875	1.500	3SS	2.625	.562							
3470AV	C	2.875	1.500	3SS	2.625	.562	1040	K	2.625	2.125	3SS	2.750	.500
3475AN	C	2.875	1.250	51/2S	3.437	PLT	1265A	K	2.625	2.125	2SS	2.750	.500
3480A	C	2.875	1.125	3SS	3.000	.359	1266A	K	2.625	2.125	3C	2.750	.500
3480AV	C	2.875	1.125	3SS	3.000	.359	2143	K	2.625	2.125	1C	2.750	.500
3485AN	C	2.875	3.375	51	4.219	PLT	3465A	K	2.625	2.125	2SS	2.937	.437
3721	C	2.875	1.062	3	2.750	.500	4853AN	K	2.625	2.125	3SS	2.875	.500
3810V	C	2.875	1.250	1	2.750	.500	7196	K	2.875	2.125	3	2.750	.500
3990	C	2.875	1.500	1C	2.750	.437							
3995A	C	2.875	2.125	1C	2.750	.437							
4015	C	2.875	1.062	3	2.750	.500	1951AN	L-1	2.875	2.375	----	----	----
4058	C	2.875	1.500	1	2.750	.500	3430AN	L-1	3.062	1.750	----	----	----
4080A	C	2.687	2.125	1C	2.687	.469	3435AN	L-1	3.062	1.750	----	----	----
4185A	C	2.875	1.250	3SS	2.750	.794	6635AN	L-1	2.625	2.375	----	----	----
4187A	C	2.875	1.500	3SS	2.750	.625							
4255AN	C	2.875	1.500	3SS	2.750	.497							
6085AN	C	2.875	1.750	2SS	2.875	.406							
6155AN	C	2.875	1.500	51	4.312	PLT	3406AN	L-2	2.625	2.000	----	----	----
6165AN	C	2.875	2.125	51	4.312	PLT	8025AN	L-2	2.625	2.750	----	----	----
6212	C	2.875	1.500	1	2.750	.500							
6213	C	2.875	1.500	1	2.750	.500							
6218	C	2.875	1.500	1	2.750	.500							
6224	C	2.875	1.500	1	2.750	.500							
6238	C	2.875	1.062	3	2.750	.500							
6247	C	2.875	1.062	3	2.750	.500	658	R	3.000	2.125	1SS	2.750	.500
6247V	C	2.875	1.062	3	2.750	.500	1610	R	3.000	2.125	1C	2.750	.500
6695AN	C	2.875	1.500	2SS	2.875	.500							
7100A	C	2.875	1.500	1C	2.750	.438							
7105A	C	2.875	1.750	2SS	2.875	.406	3413A	T	2.598	1.875	1C	2.750	.500
7781	C	2.875	1.062	1	2.750	.500							
7781SCTC	C	2.875	1.062	1	2.750	.500							
8315A	C	2.875	1.750	2SS	2.937	.500							

Part No.	Type	O.D.	OP. Height	Type	C' Bore	Thk.	Part No.	Type	O.D.	OP. Height	Type	C' Bore	Thk.
<b>2.000 SHAFT</b>							<b>2.125 SHAFT (54MM)</b>						
<b>ROTARY</b>				<b>SEAT</b>			<b>ROTARY</b>				<b>SEAT</b>		
385A	U	2.625	2.500	3SS	2.750	.500	327	E	2.812	2.375	3C	3.000	.562
386	U	2.625	2.500	3SS	2.812	.500	353	E	2.812	2.375	2SS	3.000	.625
456	U	2.625	2.218	3SS	2.750	.500	537	E	2.812	2.375	1C	3.000	.562
888	U	2.625	2.437	3C	2.625	.500	611	E	2.812	2.375	3C	2.812	.437
							612	E	2.812	2.250	3SS	2.812	.437
							856	E	2.812	2.375	3C	2.875	.562
3418AV	Z	3.250	.950	SEAT UNITIZED WITH SEAL			857	E	2.812	2.375	3SS	2.875	.562
							1612	E	2.812	2.250	3SS	2.812	.437
							1612V	E	2.812	2.250	3	2.812	.437
							1617	E	2.812	2.375	3C	3.000	.562
							1666	E	2.812	2.375	3SS	3.000	.562
<b>2.062 SHAFT</b>							<b>2.125 SHAFT (54MM)</b>						
707	E	2.812	2.375	3SS	2.875	.562	2084	E	2.812	2.375	1C	3.000	.562
1611	E	2.812	2.375	3C	2.875	.562	2085	E	2.812	2.375	1SS	3.000	.562
3487A	E	2.812	2.375	3SS	2.875	.562	2086	E	2.812	2.375	3SS	3.000	.562
							2159	E	2.812	2.375	1SS	3.000	.562
							3490A	E	2.812	1.750	2SS	3.000	.500
3421AV	Z	3.500	.875	SEAT UNITIZED WITH SEAL			3490AV	E	2.812	1.750	2SS	3.000	.500
3422AV	Z	3.500	.875	SEAT UNITIZED WITH SEAL			3492A	E	2.812	2.375	1C	3.000	.625
							3513A	E	2.812	1.750	3C	3.000	.500
							3514A	E	2.812	1.750	3C	3.000	.562
<b>2.125 SHAFT (54MM)</b>							<b>2.125 SHAFT (54MM)</b>						
336	C	3.000	1.687	2SS	3.000	.562	5125SSA	E	2.812	3.000	3SS	3.000	.562
338	C	3.000	1.687	3C	3.000	.562	9964A	E	2.812	1.750	3C	2.875	.562
338LS	C	3.000	2.375	3C	3.000	.562	9966A	E	2.812	1.750	3SS	2.875	.562
338V	C	3.000	1.687	3	3.000	.562	9968A	E	2.812	2.375	3SS	2.875	.625
543	C	3.000	1.687	1SS	3.000	.625	8035A	E	2.812	1.500	2SS	3.000	.500
543V	C	3.000	1.687	3	3.000	.562	8105A	E	2.812	1.750	2SS	3.000	.500
844	C	3.000	1.687	1C	3.000	.562							
854	C	3.000	1.687	3C	2.875	.562	887	K	3.000	2.125	1C	3.000	.562
855	C	3.000	1.687	3SS	2.875	.562							
1057B/V	C	3.000	1.687	3SS	3.000	.562							
3495AN	C	3.000	3.000	2SS	3.000	.500	4792A	L-2	2.812	1.625	25CA	3.143	1.031
3500AN	C	3.000	2.000	2B	3.000	.500	4792AV	L-2	2.812	1.625	25CA	3.143	1.031
3505A	C	3.000	1.000	3SS	3.250	.500	4799A	L-2	2.812	1.625	25CA	3.187	.844
3510A	C	3.000	1.000	2SS	3.000	.375							
3510AE	C	3.000	1.000	2SS	3.000	.375							
3510AV	C	3.000	1.000	2SS	3.000	.375	2126	T	2.812	3.375	1C	3.000	.562
3520AN	C	3.000	2.125	51	3.625	PLT							
3521AN	C	3.000	1.687	51	4.250	PLT							
3525AN	C	3.000	1.687	51	4.250	PLT	457	T/U	2.812	3.656	1C	3.000	.562
5700AN	C	3.000	1.687	2SS	2.844	.468							
6110A	C	3.000	2.000	1SS	2.812	.469							
6120A	C	3.000	2.000	1SS	2.812	.469	556	U	2.812	2.375	2SS	3.000	.562
6120AV	C	3.000	2.000	1SS	2.812	.469	556SS	U	2.812	2.375	2SS	3.000	.562
							5126A	U	2.812	3.000	3SS	3.000	.562
1686	D	3.250	1.687	1C	3.000	.562							
1687	D	3.250	1.687	1SS	3.000	.562	1102	V	2.750	2.562	25C	3.140	.562
2087	D	3.250	1.687	1C	3.000	.562	1107	V	2.750	1.625	25C	3.187	.875
2088	D	3.250	1.687	1SS	3.000	.562							
2089	D	3.250	1.687	3C	3.000	.562							
2090	D	3.250	1.687	3SS	3.000	.562	3497AV	Z	3.500	.875	SEAT UNITIZED WITH SEAL		
2093	D	3.250	1.687	3C	3.000	.562	3498AV	Z	3.500	.875	SEAT UNITIZED WITH SEAL		
2102	D	3.250	1.687	3SS	3.000	.562							
2125	D	3.250	1.687	2SS	3.000	.562							
3515AN	D	3.250	1.125	51	3.625	PLT							

Part No.	Type	O.D.	OP. Height	Type	C' Bore	Thk.	Part No.	Type	O.D.	OP. Height	Type	C' Bore	Thk.
<b>2.187 SHAFT</b>							<b>2.250 SHAFT</b>						
<b>ROTARY SEAT</b>							<b>ROTARY SEAT</b>						
3530A	C	3.000	1.375	2SS	3.187	.375	3535AN	K	3.125	1.500	2/51	3.250	PLT
4385AV	C	3.000	1.375	2SS	3.187	.375	3536AN	K	3.125	1.500	2SS	3.000/3.250	PLT
							7431	K	3.125	1.875	1	3.125	.562
							7766	K	3.125	2.125	3	3.125	.562
3003AV	D	3.250	1.000	2SS	3.000	.406	3550AN	L-2	2.875	2.500	----	----	----
4785A	D	3.250	1.000	2SS	3.000	.406							
4785AE	D	3.250	1.000	2SS	3.000	.406							
							1073N	R	3.375	2.375	3SS	3.125	.562
<b>2.250 SHAFT</b>							<b>2.312 SHAFT</b>						
1068AN	C	3.125	2.250	1SS	3.147	.438	2132	T	2.938	3.375	3C	3.125	.562
1068AV	C	3.125	2.250	1SS	3.147	.438	3562A	T	2.938	1.875	3C	3.125	.562
1087	C	3.125	1.437	1C	3.125	.562							
1676	C	3.125	1.688	3SS	3.125	.562	<b>2.312 SHAFT</b>						
1676E	C	3.125	1.688	3	3.125	.562	3590AN	C	3.125	1.688	----	----	----
1676V	C	3.125	1.688	3	3.125	.562							
1678	C	3.125	1.688	3C	3.125	.562	<b>2.375 SHAFT</b>						
1678V	C	3.125	1.688	3	3.125	.562	268	C	3.219	1.813	3C	3.250	.562
1679	C	3.125	1.688	1C	3.125	.562	268VHD	C	3.219	1.813	3	3.250	.562
1679V	C	3.125	1.688	1	3.125	.562	492	C	3.219	1.813	3SS	3.250	.562
1680	C	3.125	1.688	1SS	3.125	.562	492HD	C	3.219	1.813	3	3.250	.562
1680SCSC	C	3.125	1.688	1	3.125	.562	1026AN	C	3.219	1.813	52	----	PLT
3537	C	3.125	2.375	1	3.125	.562	1677	C	3.219	1.813	51	----	PLT
3540A	C	3.125	1.125	2SS	3.125	.438	3595AN	C	3.219	2.500	1C	3.250	.562
3543AV	C	3.125	1.688	2SS	3.125	.532	3596A	C	3.219	2.500	1C	3.250	.562
3544A	C	3.125	.875	3B	3.125	.562	3596AV	C	3.219	2.500	2SS	3.250	.562
3560AN	C	3.125	1.688	2B	3.125	.532	3605A	C	3.219	1.813	2SS	3.250	.562
3560AV	C	3.125	1.688	2B	3.125	.532	3605AV	C	3.219	1.813	2SS	3.250	.562
3570AN	C	3.125	2.250	----	----	----	3610AN	C	3.219	1.000	----	----	----
3580AN	C	3.125	2.250	2SS	3.125	.438	3615AN	C	3.219	2.500	2SS	3.250	.563
3773	C	3.125	1.688	1	3.125	.562	3615AV	C	3.219	2.500	2SS	3.250	.563
3966	C	3.125	1.187	3	3.125	.562							
4585A	C	3.125	1.437	1C	3.250	.500							
6233	C	3.125	1.695	3	3.125	.500	594	D	3.500	1.812	3SS	3.250	.562
6248	C	3.125	1.187	3	3.125	.562	834	D	3.500	1.812	3C	3.250	.562
6660AN	C	3.125	3.750	----	----	----	2095	D	3.500	1.812	3SS	3.250	.562
7064	C	3.125	1.437	1	3.125	.562	2096	D	3.500	1.812	3C	3.250	.562
7110A	C	3.125	1.688	2SS	3.125	.532							
7138	C	3.125	1.187	1	3.125	.562	278	E	3.062	2.500	3C	3.250	.562
7138TCTC	C	3.125	1.187	1	3.125	.562	278V	E	3.062	2.500	3	3.250	.562
7782	C	3.125	1.688	1	3.125	.562	350	E	3.062	2.500	3SS	3.250	.562
7945AN	C	3.125	2.250	51	----	PLT	2097	E	3.062	2.500	3C	3.250	.562
							2098	E	3.062	2.500	3SS	3.250	.562
							2098V	E	3.062	2.500	3	3.250	.562
846	D	3.375	1.688	3C	3.125	.562	1041	K	3.219	2.125	3SS	3.250	.562
847	D	3.375	1.688	3SS	3.125	.562	1694	K	3.219	2.125	3C	3.250	.562
874	D	3.375	1.688	1C	3.125	.562							
941	D	3.375	1.688	1SS	3.125	.562	<b>2.406 SHAFT (61MM)</b>						
941V	D	3.375	1.688	3	3.125	.562	4854AN	K	3.219	2.125	3SS	3.312	.500
942	D	3.375	1.688	----	----	----							
2087	D	3.375	1.688	1C	3.125	.562	<b>2.437 SHAFT (62MM)</b>						
2088	D	3.375	1.688	1SS	3.125	.562	3625A	C	3.219	1.500	3SS	3.437	.562
2089	D	3.375	1.688	3C	3.125	.562	3626A	C	3.219	1.813	2SS	3.437	.625
2090	D	3.375	1.688	3SS	3.125	.562	7950an	C	3.219	1.813	51	----	PLT
323	E	2.938	2.375	1C	2.375	.562							
351	E	2.938	2.375	1SS	2.375	.562							
351V	E	2.938	2.375	3	3.125	.562							
848	E	2.938	2.375	3C	2.375	.562							
849	E	2.938	2.375	3SS	2.375	.562							
1688	E	2.938	2.375	3C	2.375	.562							
2091	E	2.938	2.375	1C	2.375	.562							
2092	E	2.938	2.375	1SS	2.375	.562							
2094	E	2.938	2.375	3SS	2.375	.562							
2094V	E	2.938	2.375	3	3.125	.562							
2113	E	2.938	2.375	----	----	----							
3530	E	2.938	2.375	3	3.125	.562							
3643	E/Bal.	2.938	2.750	3	3.000	.562							
3784	E/Bal.	2.938	2.750	3	3.000	.562							
7749	E/Bal.	2.938	2.750	3	3.000	.562							

Part No.	Type	O.D.	OP. Height	Type	C' Bore	Thk.	Part No.	Type	O.D.	OP. Height	Type	C' Bore	Thk.
<b>2.437 SHAFT (62MM)</b>							<b>2.500 SHAFT</b>						
<b>ROTARY</b>				<b>SEAT</b>			<b>ROTARY</b>				<b>SEAT</b>		
3624A	D	3.500	1.175	3SS	3.875	.468	6640AN	L-1	3.125	2.000	----	----	----
3627AV	Z	3.750	.875	SEAT UNITIZED WITH SEAL			3670AN	L-2	3.125	2.625	----	----	----
<b>2.500 SHAFT</b>							889N	R	3.625	2.187	3SS	3.375	.531
269	C	3.344	1.813	3C	3.375	.562	3652A	T	3.187	2.125	1C	3.375	.562
853	C	3.344	1.813	3SS	3.375	.562	6243	T	3.187	2.656	3	3.500	.422
1058	C	3.344	1.813	3SS	3.375	.562	6244	T	3.187	2.656	3	3.500	.422
2120	C	3.344	1.813	1C	3.375	.562	6257	T	3.187	2.656	3	3.500	.422
2158	C	3.344	2.125	1C	3.375	.562	8044AV	U	3.187	.800	7SS	M.O.S.	.312
3630AN	C	3.344	1.500	51	4.500	PLT	2147	V	3187	2.375	3C	3.500	.562
3645AN	C	3.344	3.000	51	3.750	PLT	<b>2.625 SHAFT</b>						
3650A	C	3.344	1.500	2SS	3.500	.468	571	C	3.469	2.732	3SS	3.336	.531
3679A	C	3.344	2.500	3C	3.375	.562	1051A	C	3.469	1.125	3SS	4.000	.434
3680A	C	3.344	2.375	2SS	3.375	.562	3695AN	C	3.469	2.732	2SS	3.500	.500
3681AN	C	3.344	3.000	2SS	3.375	.500	3705AN	C	3.469	2.732	2SS	3.625	.437
4075A	C	3.344	1.250	3SS	3.500	.562	8060AN	C	3.469	2.732	2SS	3.437	.687
4085A	C	3.344	1.813	3SS	3.375	.375	9917AV	C	3.469	1.125	3B	4.000	.496
4230A	C	3.344	2.375	----	----	----	7888AV	D	3.750	1.125	3SS	3.750	.565
4465AN	C	3.344	1.500	3SS	3.500	.562	7909	D	3.875	1.937	3	3.375	.625
6095AN	C	3.344	1.813	2SS	3.375	.500	328	E	3.375	2.750	3C	3.375	.625
8045A	C	3.344	1.813	2SS	3.625	.500	328HD	E	3.375	2.750	3	3.375	.625
8055A	C	3.344	1.375	2SS	3.375	.469	542	E	3.375	2.750	3SS	3.375	.625
335N	D	3.625	1.250	3SS	3.375	.562	7703	E/Bal.	3.375	3.125	3	3.375	.562
463	D	3.625	1.813	3SS	3.375	.562	7773	E/Bal.	3.375	3.125	3	3.375	.562
468	D	3.625	1.813	3C	3.250	.437	7927	E/Bal.	3.375	3.125	3	3.375	.562
469	D	3.625	1.813	3SS	3.250	.437	4797A	L-2	3.500	1.625	25CA	3.645	.562
481	D	3.625	1.750	3SS	3.500	.562	1106	V	3.375	2.562	25C	3.643	.562
835	D	3.625	1.813	3C	3.375	.562	<b>2.687 SHAFT</b>						
2099	D	3.625	1.813	3C	3.375	.562	3710A	C	3.469	1.375	2SS	3.937	.438
2100	D	3.625	1.813	3SS	3.375	.562	<b>2.750 SHAFT</b>						
3625	D	3.625	1.813	1	3.375	.562	483	C	3.750	1.937	3SS	3.500	.625
3631AN	D	3.625	1.250	3SS	3.375	.562	483VTC	C	3.750	1.937	3	3.500	.625
3888	D	3.625	1.813	3	3.375	.562	836	C	3.750	1.937	3C	3.500	.625
279	E	3.187	2.500	3C	3.375	.562	836SS	C	3.750	1.300	3C	3.500	.625
349	E	3.187	2.500	3SS	3.375	.562	1058AN	C	3.750	1.375	51	4.500	PLT
349HD	E	3.187	2.500	3	3.375	.562	2124N	C	3.750	1.937	3SS	3.500	.625
349V	E	3.187	2.500	3	3.375	.562	2152	C	3.750	1.937	3SS	3.500	.625
916	E	3.187	2.500	3C	3.375	.562	2154	C	3.750	1.125	3C	3.500	.625
916BTC	E(B)	3.187	2.500	3TC	3.250	.562	2154SCSC	C	3.750	1.125	1	3.500	.625
2101	E	3.187	2.500	3SS	3.375	.562	2154TCCTC	C	3.750	1.125	3	3.500	.625
2205	E	3.187	2.500	3	3.375	.562	2154VSCSC	C	3.750	1.125	3	3.500	.625
2205E	E	3.187	2.500	3	3.375	.562	3661	C	3.750	1.500	3	3.500	.625
3632A	E	3.187	2.500	3C	3.375	.562	3719AV	C	3.750	1.375	3SS	3.500	.500
4380AN	E	3.187	1.500	3SS	3.500	.562	3720A	C	3.750	1.937	3SS	3.312	.562
6254	E	3.187	1.813	3	3.500	.422	3727A	C	3.750	1.375	3SS	3.500	.500
7985	E	3.062	2.500	3	3.375	.562	3994	C	3.750	1.500	3	3.500	.625
3640AN	G	3344	1.625	51	----	PLT	6125	C	3.750	1.125	1	3.500	.625
1280AN	K	3.344	2.500	2SS	3.375	.500	6205	C	3.750	1.125	1	3.500	.625
1613	K	3.344	2.125	3C	3.375	.562	6207	C	3.750	1.125	3	3.500	.625
1695	K	3.344	2.125	3SS	3.375	.562	6220	C	3.750	1.125	1	3.500	.625
2158	K	3.344	2.125	1	3.375	.562	6239	C	3.750	1.500	3	3.500	.625
3635AN	K	3.344	2.125	----	----	----	8070A	C	3.750	1.937	2SS	3.500	.469
3655A	K	3.344	1.625	2SS	3.500	.468							
8050AN	K	3.344	1.625	2S/51	3.625	.438							







